

VERTI-DRAIN 7212



Version: 2424



Kwekerijweg 8 | 3709JA | Zeist | The Netherlands |
T: +31 (0)306 933 227
E: redexim@redexim.com
W: www.redexim.com



- Page 12: PTO
- Page 13: Core Collector
- Page 14: Windrow Kit
- Page 15: Tines
- Page 16: Adapters/turf hold down kit

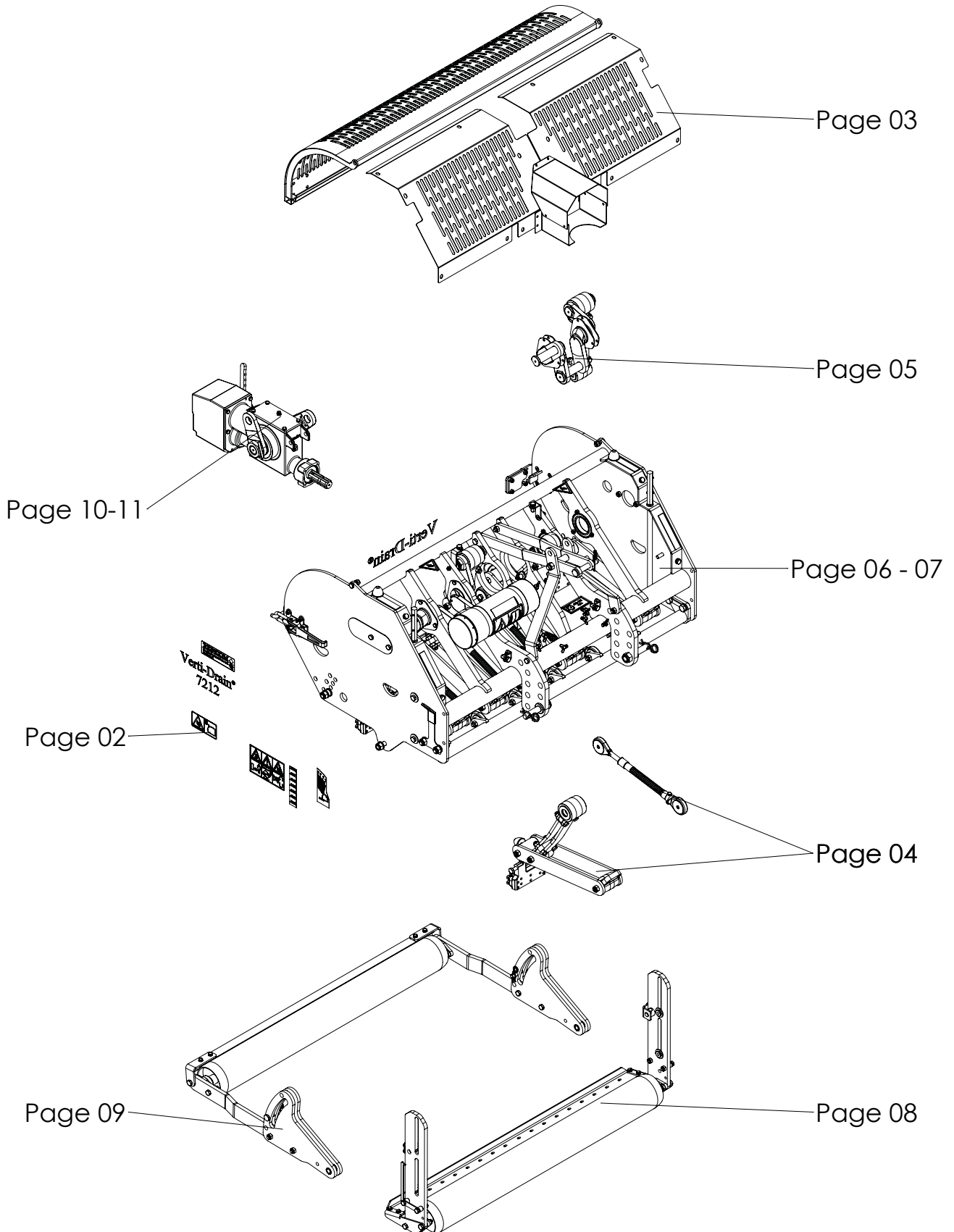

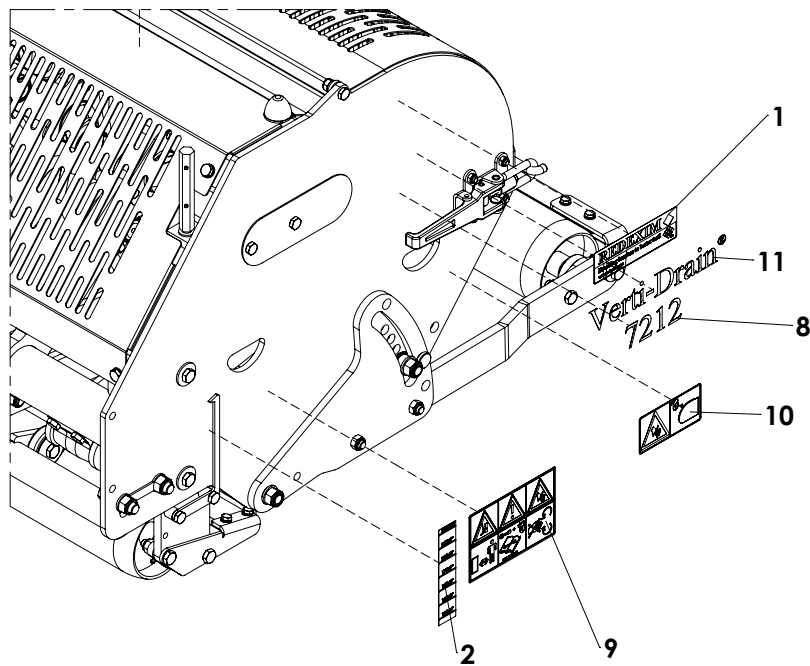
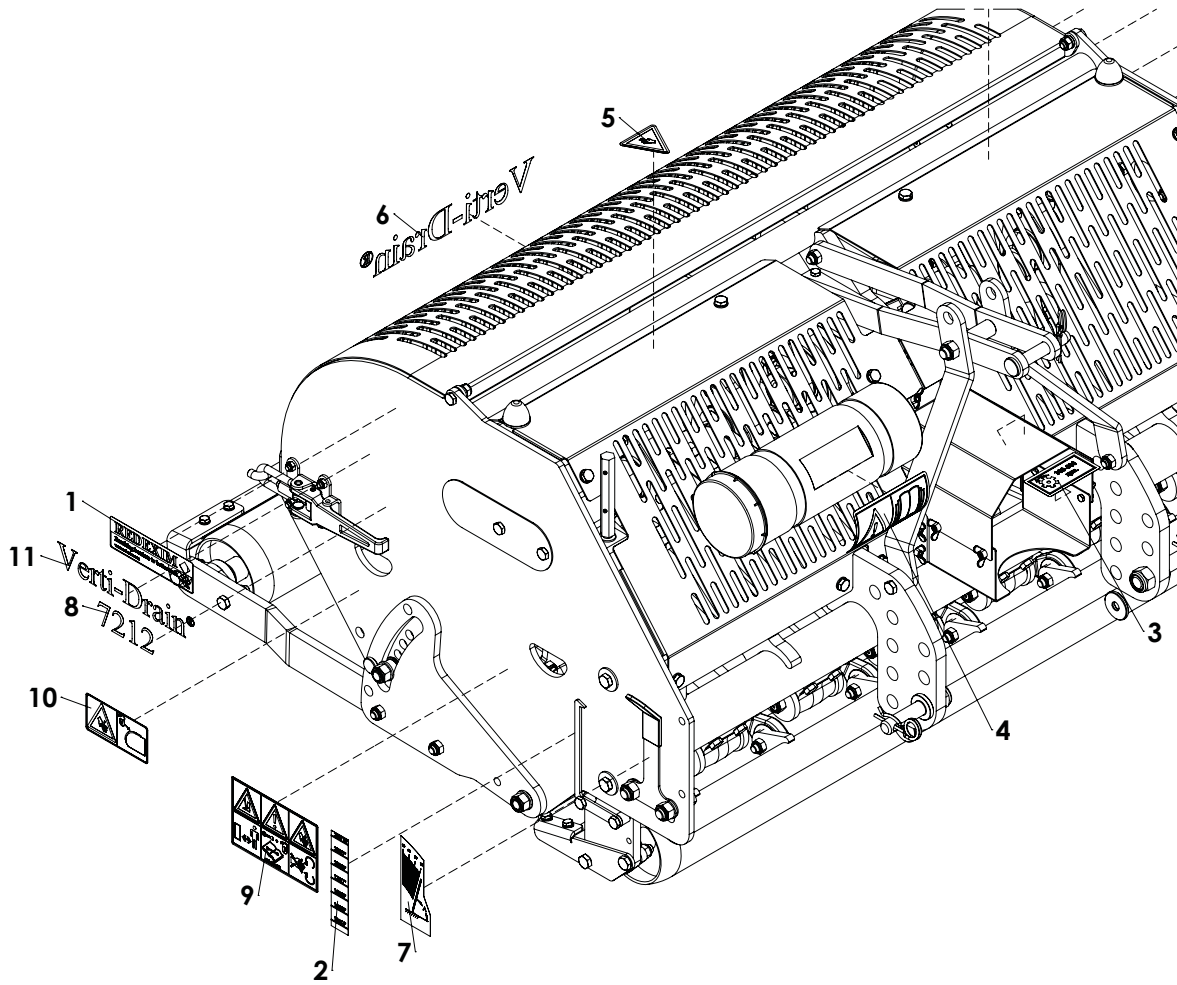

ITEM	PART NUMBER	DESCRIPTION	REMARKS	QUA
1	900.260.403	Logo Label		2
2	900.260.408	Height label 250		2
3	900.260.420	Decall PTO 300 500		1
4	900.280.402	Safety decall manual		1
5	900.280.404	Decall cut off fingers		2
6	911.260.402	Decall Verti-drain		1
7	911.260.404	Angle setting label VD		1
8	911.260.408	Label 7212		2
9	911.280.402	Safety Decall Verti-Drain		2
10	911.280.404	Decall close cover		2
11	911.260.403	Decall Verti-drain		2

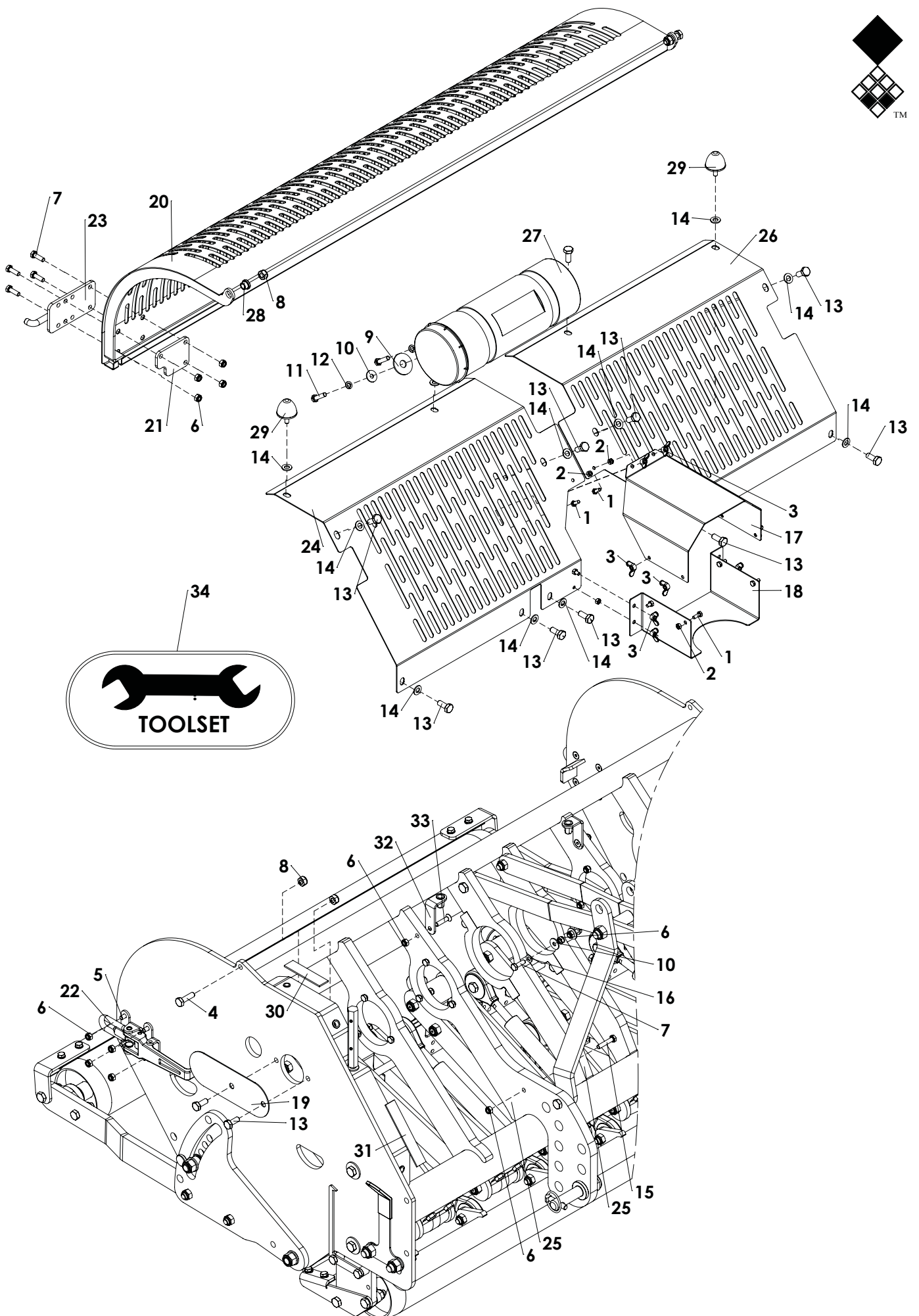

ITEM	PART NUMBER	DESCRIPTION	REMARKS	QUA
1	804.060.160	Bolt M6 x 16 - ISO 4017		10
2	826.060.060	Nut M6 - DIN 934		10
3	844.060.060	Winged nut		10
4	804.100.350	Bolt M10 x 35 - ISO 4017		2
5	816.080.250	Bolt M8x25 DIN 7991		8
6	830.080.080	Self Lock Nut M8 - ISO 10511		22
7	804.080.250	Bolt M8 x 25 - ISO 4017		10
8	830.100.100	Self Lock Nut M10 - ISO 10511		6
9	864.140.031	Large washer M14 - DIN 9021		2
10	864.080.024	Large washer M8 - DIN 9021		4
11	804.080.350	Bolt M8 x 35 - ISO 4017		2
12	866.080.020	Spring Washer M8 - DIN 127		2
13	804.100.250	Bolt M10 x 25 - ISO 4017		16
14	864.100.030	Washer M10 - ISO 7089		14
15	802.080.400	Bolt M8 x 40 - ISO 4014		2
16	864.080.030	Washer M8 - ISO 7089		2
17	2281782	TOP PTO protection cover		1
18	2281783	Bottom PTO Protection		1
19	2281736	Cover		2
20	456.128.037	Rear cover 7212		1
21	468.060.902	Rear plate		2
22	590.342.700	Clamp		2
23	470.061.710	Lock plate		2
24	456.062.037	Front cover 7212 Left		1
25	464.040.320	Bracket		4
26	456.062.038	Front cover 7212 Right		1
27	444.803.100	Toolbox Complete		1
28	404.100.122	Distance bush		2
29	446.080.550	Rubber stop		2
30	599.031.000	Foam rubber L=100		2
31	599.031.400	Foam rubber L=140		2
32	464.040.764	Bracket		2
33	816.080.350	DIN 7991 - M8 x 35 --- 35C		2
34	468.083.060	Set of tools		1

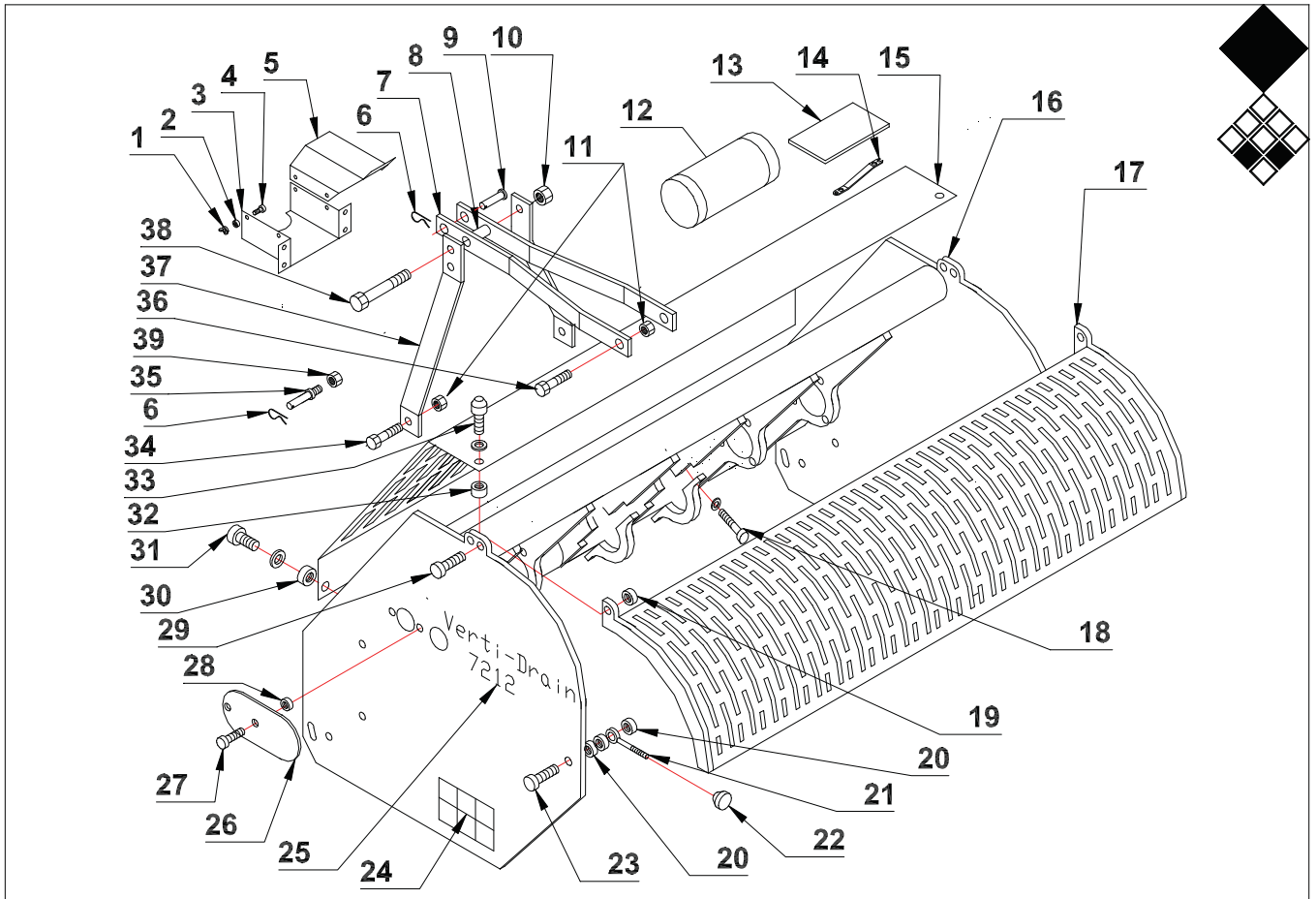

Redexim-Charterhouse Verti-Drain 7212 pag 03-1 code 0401

	PART #	DESCRIPTION	REMARKS	QUA
1	4191100	Winged nut		10
2	4100800	Self lock nut M6		10
3	2281783	Bottom PTO protection cover		1
4	4001030	Bolt M6 x 16		10
5	2281782	Top PTO protection cover		1
6	4397008	R pin		3
7	2251388	Top linkage strip		2
8	2611518	Distance bush top link		1
9	2490825	Top link pin		1
10	4123800	Self lock nut M16		1
11	4122600	Self lock nut M12		4
12	9100030	Manual/ tool box complete		1
13	9100004	Operators and parts manual 7212		1
14	9100025	Combi tool		1
15	2211492	Front cover 7212		1
16	2305998	Main frame 7212		1
17	2282178	Rear cover 7212		1
18	4012114	Gearbox fix bolt 7212		4
19	4122000	Self lock nut M10		2
20	4122000	Self lock nut M10		6
21	4091050	Eye bolt		2
22	2891200	Knurled nut		2
23	4001688	Bolt M 10 x 50		2
24	9100002	Set safety decalls		1
25	9100000	Set machine decalls for 7212		1
26	2281736	Protection plate		2
27	4001644	Bolt M10 x 25		4
28	4122000	Self lock nut M10		4
29	4001653	Bolt M10 x 30		2
30	4122000	Self lock nut M10		6
31	4001644	Bolt M10 x 25		6
32	4121400	Self lock nut M8		2
33	4972008	Rubber stop		2
34	4001858	Bolt M12 x 45		2
35	2490881	3-point bottom pin		2
36	4001866	Bolt M12 x 50		2
37	2251384	Top linkage support strip		2
38	4002408	Bolt M16 x 120		1
39	4125800	Self lock nut M 22		2

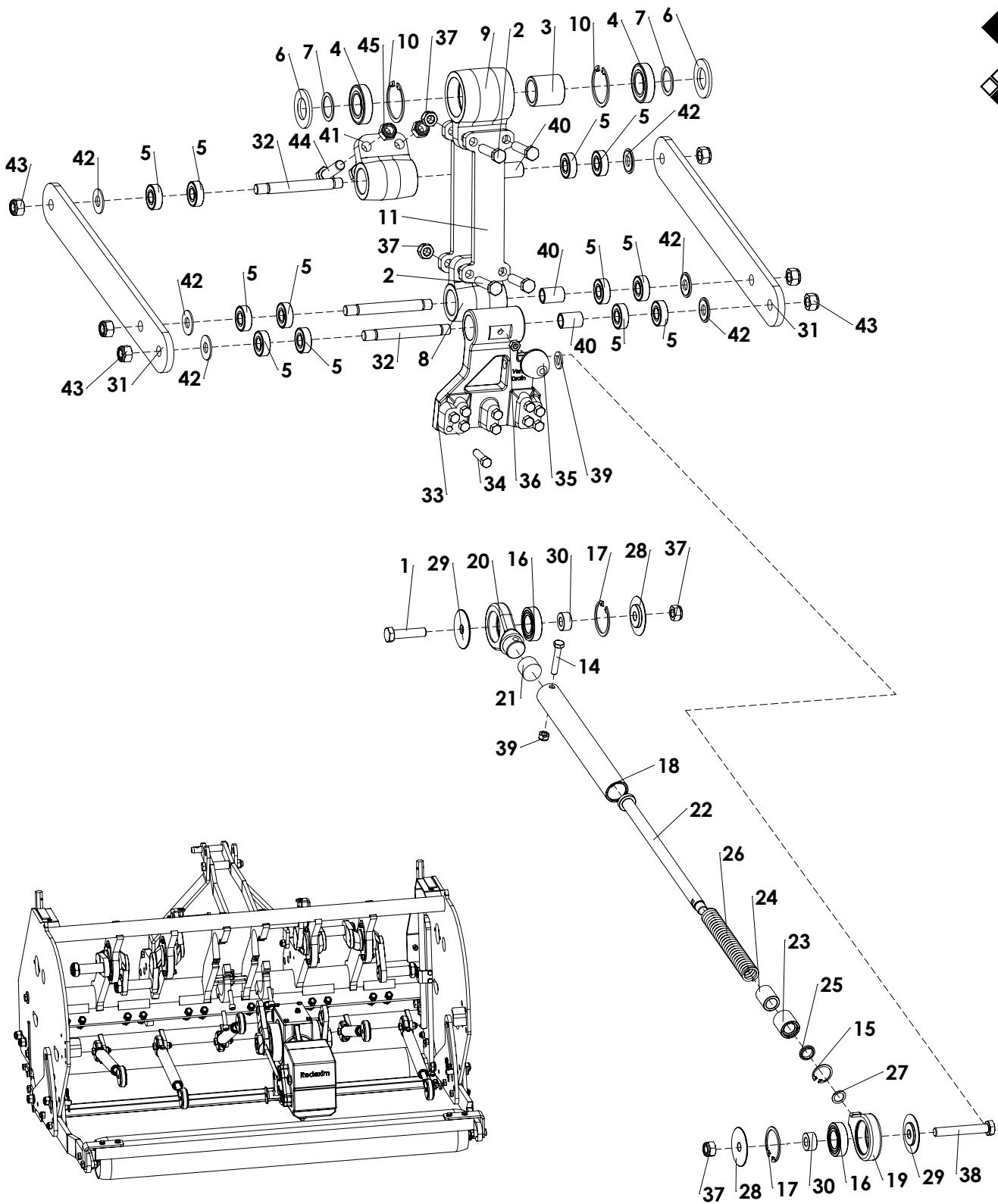

Apply 20ml grease inside drawrod

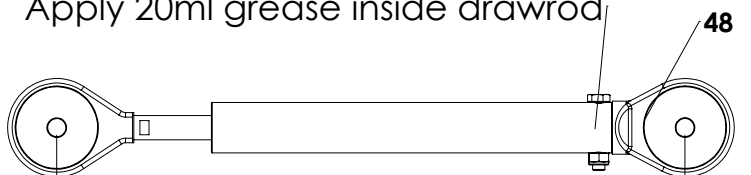

415 \pm 2 (16.34"-16.42")

Use shim 864.140.012 to create correct length

ITEM	PART NUMBER	DESCRIPTION	REMARKS	QUA
1	802.120.500	Bolt M12 x 50 - ISO 4014 - 10.9		1
2	802.120.550	Bolt M12 x 55 - ISO 4014 - 10.9		4
3	2603043	Inner bush big end		1
4	713.300.130	Bearing 6006-LLU		2
5	713.150.110	Bearing 6202-LLU		12
6	2661220	Dust cover		2
7	2661222	Distance washer		2
8	2431308	Bearing support	Replaces version with 2x circlip 872.035.150	1
9	492.750.750	Big end		1
10	872.055.200	Circlip D=55 - DIN 472		2
11	2381854	Connecting plate outer		4
12	2381852	Connecting plate middle		4
13	2381856	Connecting plate centre		4
14	802.080.450	Bolt M8 x 45 - ISO 4014		1
15	872.028.130	Circlip D=28 - DIN 472		1
16	713.250.120	Bearing 6005-LLU		2
17	872.047.180	Circlip DIN 472 - 47 x 1.75		2
18	2381858	Tube for drawrod		1
19	448.640.820	Draw rod head with hole		1
20	448.640.960	Draw rod head with stud		1
21	446.280.200	Rubber stop		1
22	2282139	Draw rod		1
23	442.180.300	Bearing bush		1
24	406.180.200	Distance bush		1
25	761.160.030	Seal		1
26	4781204	Compression spring		1
27	864.140.012	Shim S=1	Use as many to calibrate	1
28	404.120.050	Dust washer Ø55/Ø32/Ø12 L=5.2		2
29	404.120.040	Dust washer Ø55/Ø32/Ø12 L=4.25		2
30	406.120.120	Distance bush Ø25/Ø12 L=12		2
31	2941201	Element strip		2
32	2490415	Support axis		3
33	492.521.730	Tineholder		1
34	4001675	Tine holder bolt M10x35		10
35	446.080.550	Rubber stop		1
36	826.080.080	Nut M8 - DIN 934		6
37	830.120.120	Self Lock Nut M12 - ISO 10511 Class 10		6
38	802.120.800	Bolt M12 x 80 - ISO 4014		1
39	864.120.030	Washer M12 - ISO 7089		1
40	2601530	Inner bush		3
41	448.075.088	Bearing support	Check mounting holes Ø14.2mm (0.46")	1
	2431308	Bearing support	Check mounting holes Ø12.2mm (0.48")	1
42	412.150.050	Distance washer		6
43	830.140.140	Self Lock Nut M14 10.9 - ISO 10511		6
44	802.140.550	Bolt M14 x 55 - ISO 4014 - 10.9	Check diameter 14mm (0.55")	2
	802.120.550	Bolt M12 x 55 - ISO 4014 - 10.9	Check diameter 12mm (0.47")	2
45	830.140.140	Self Lock Nut M14-ISO 10511 Class 10	Check diameter 14mm (0.55")	2
	830.120.120	Self Lock Nut M12 10.9 - ISO 10511	Check diameter 12mm (0.47")	2
46	490.344.152	Drawrod complete	total needed	6

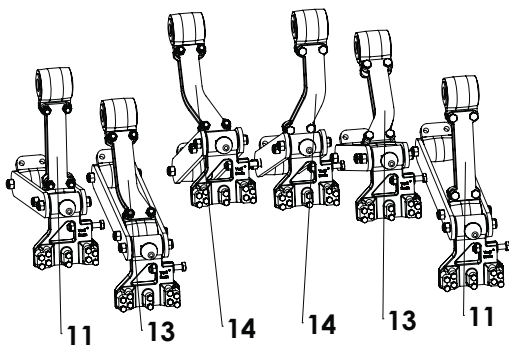
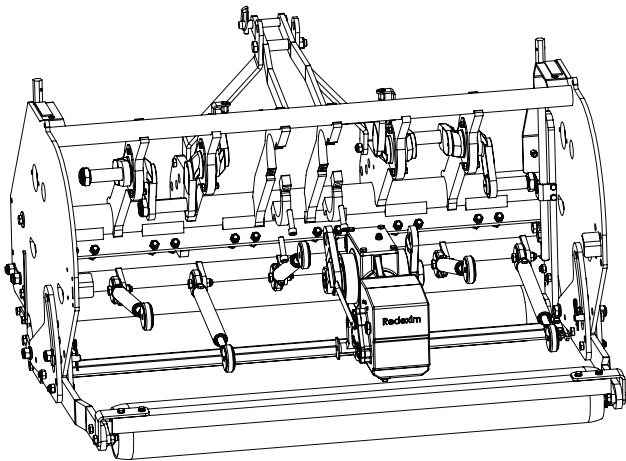
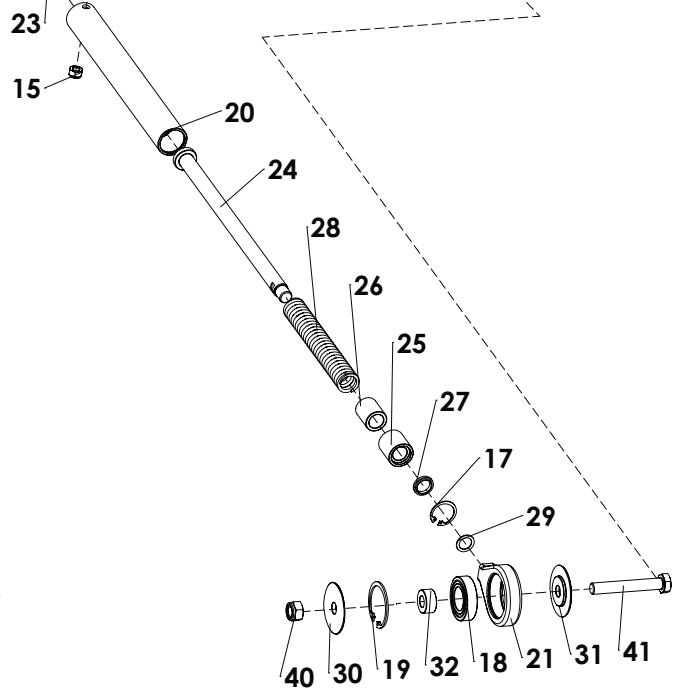
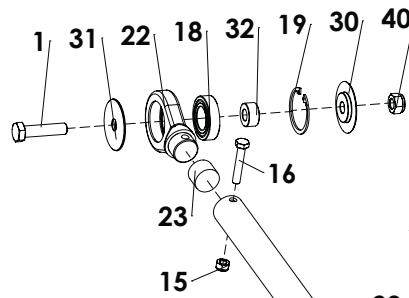
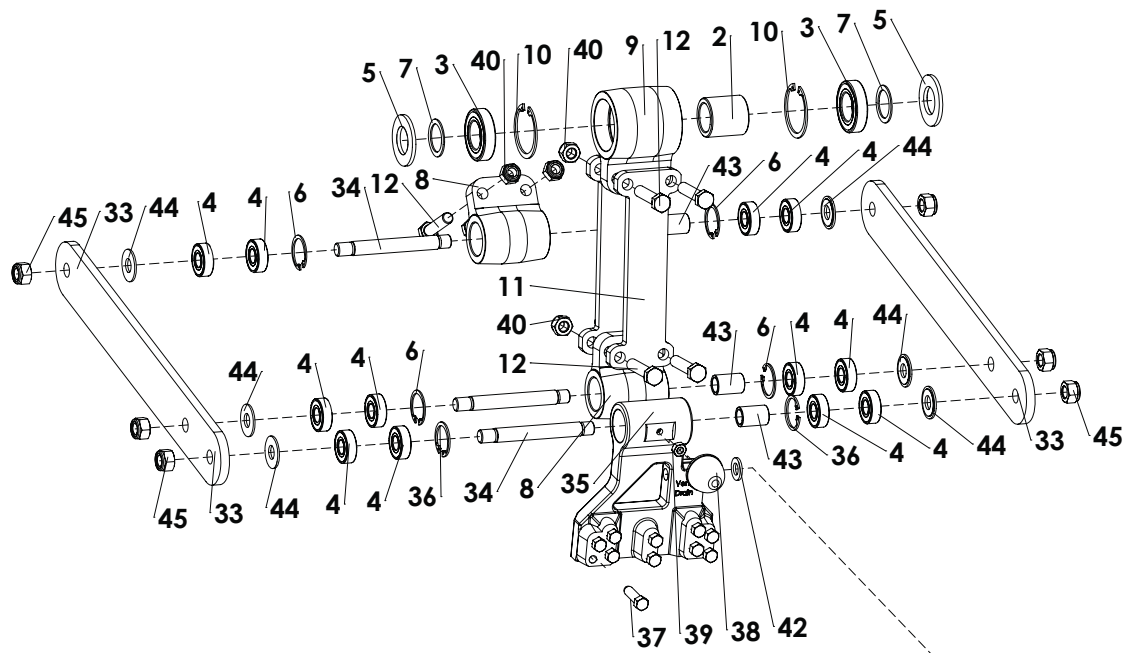

Apply 20ml grease inside drawrod

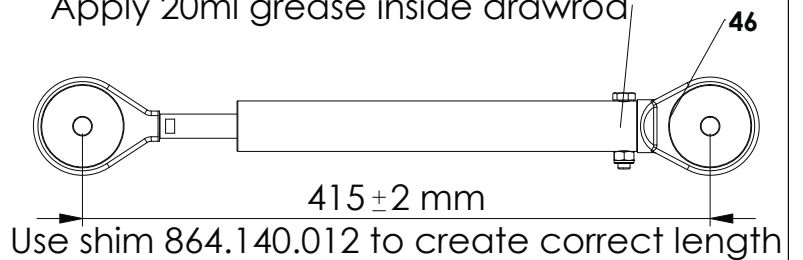

ITEM	PART NUMBER	DESCRIPTION	REMARKS	QUA
1	802.120.500	Bolt M12 x 50 - ISO 4014	Quantity for 1 element	1
2	2603043	Inner bush big end	Quantity for 1 element	1
3	713.300.130	Bearing 6006-LLU	Quantity for 1 element	2
4	713.150.110	Bearing 6202-LLU	Quantity for 1 element	12
5	2661220	Dust cover	Quantity for 1 element	2
6	872.035.150	Circlip D=35 - DIN 472	Quantity for 1 element	4
7	2661222	Distance washer	Quantity for 1 element	2
8	2431308	Bearing support	Quantity for 1 element	2
9	492.750.750	Big end	Quantity for 1 element	1
10	872.055.200	Circlip D=55 - DIN 472	Quantity for 1 element	2
11	2381854	Connecting plate outer	Quantity for 1 element	2
12	802.120.550	Bolt M12 x 55 - ISO 4014 Class 8.8	Quantity for 1 element	6
13	2381852	Connecting plate middle	Quantity for 1 element	2
14	2381856	Connecting plate centre	Quantity for 1 element	2
15	830.080.080	Self Lock Nut M8 - ISO 10511	Quantity for 1 element	1
16	802.080.450	Bolt M8 x 45 - ISO 4014	Quantity for 1 element	1
17	872.028.130	Circlip D=28 - DIN 472	Quantity for 1 element	1
18	713.250.120	Bearing 6005-LLU	Quantity for 1 element	2
19	872.047.180	Circlip D=47 - DIN 472	Quantity for 1 element	2
20	2381858	Tube for drawrod	Quantity for 1 element	1
21	448.640.820	Draw rod head with hole	Quantity for 1 element	1
22	448.640.960	Draw rod head with stud	Quantity for 1 element	1
23	446.280.200	Rubber stop	Quantity for 1 element	1
24	2282139	Draw rod	Quantity for 1 element	1
25	442.180.300	Bearing bush	Quantity for 1 element	1
26	406.180.200	Distance bush	Quantity for 1 element	1
27	761.160.030	Seal	Quantity for 1 element	1
28	4781204	Compression spring	Quantity for 1 element	1
29	864.140.012	Shim S=1	Quantity for 1 element	1
30	404.120.050	Dust washer Ø55/Ø32/Ø12 L=5.2	Quantity for 1 element	2
31	404.120.040	Dust washer Ø55/Ø32/Ø12 L=4.25	Quantity for 1 element	2
32	406.120.120	Distance bush Ø25/Ø12 L=12	Quantity for 1 element	2
33	2941201	Element strip	Quantity for 1 element	2
34	2490415	Support axis	Quantity for 1 element	3
35	492.521.730	Tineholder	Quantity for 1 element	1
36	872.035.170	Circlip DIN 472 35x1.75	Quantity for 1 element	2
37	4001675	Tine holder bolt M10x35	Quantity for 1 element	10
38	446.080.550	Rubber stop	Quantity for 1 element	1
39	826.080.080	Nut M8 - DIN 934	Quantity for 1 element	1
40	830.120.120	Self Lock Nut M12 - ISO 10511	Quantity for 1 element	6
41	802.120.800	Bolt M12 x 80 - ISO 4014	Quantity for 1 element	1
42	864.120.030	Washer M12 - ISO 7089	Quantity for 1 element	1
43	2601530	Inner bush	Quantity for 1 element	3
44	412.150.050	Distance washer	Quantity for 1 element	6
45	830.140.140	Self Lock Nut M14 - ISO 10511	Quantity for 1 element	6
46	490.344.152	Drawrod complete		

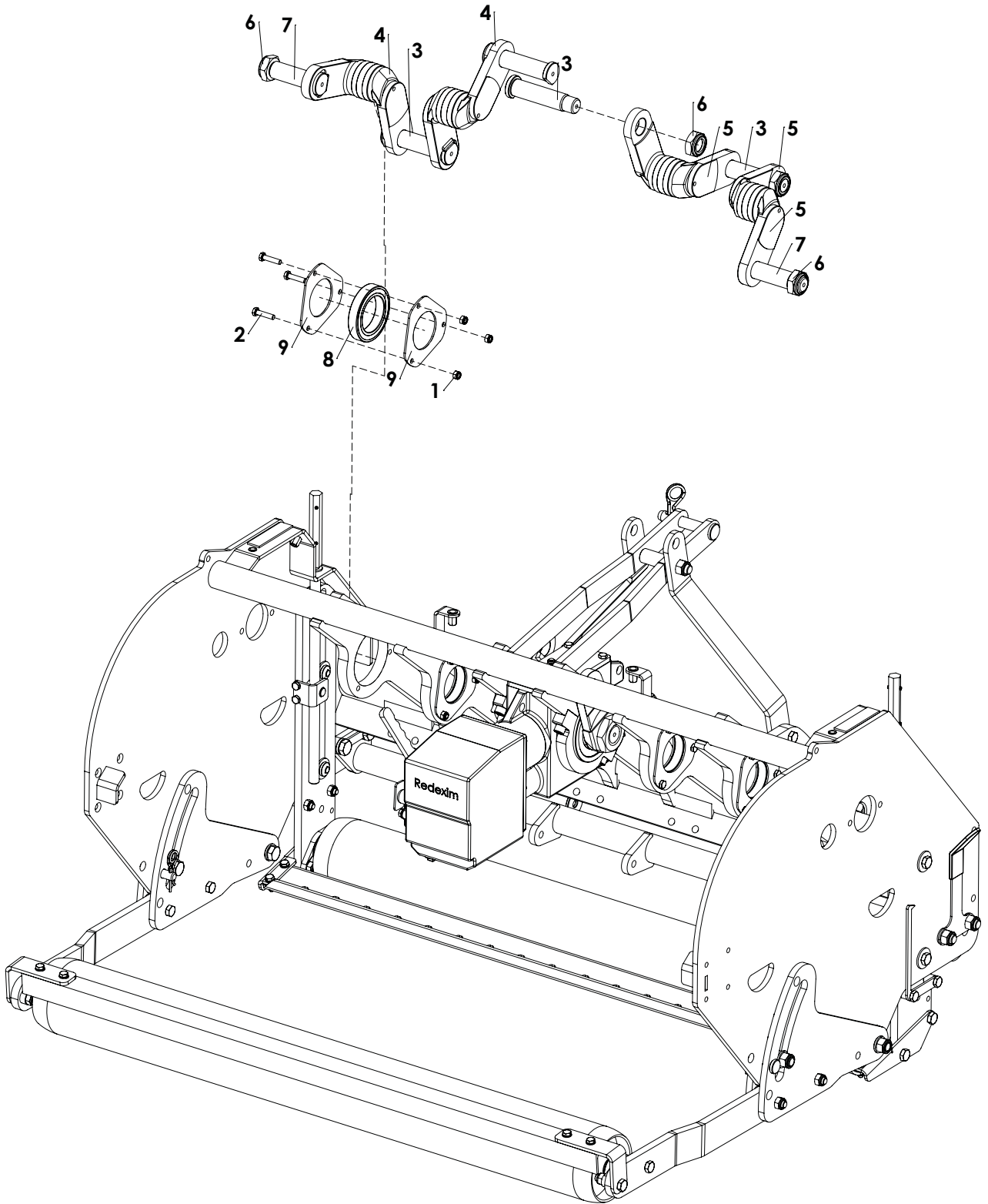

ITEM	PART NUMBER	DESCRIPTION	REMARKS	QUA
1	830.080.080	Self Lock Nut M8 - ISO 10511		12
2	802.080.350	Bolt M8 x 35 - ISO 4014		12
3	2490120	Big end pin		4
4	2441004	Right hand crank 7212		2
5	2441006	Left hand crank 7212		2
6	834.270.180	Self lock nut M27		6
7	2490110	Big end pin outer		2
8	713.650.180	Bearing 6013 LLU		4
9	468.031.300	Crank cover		8

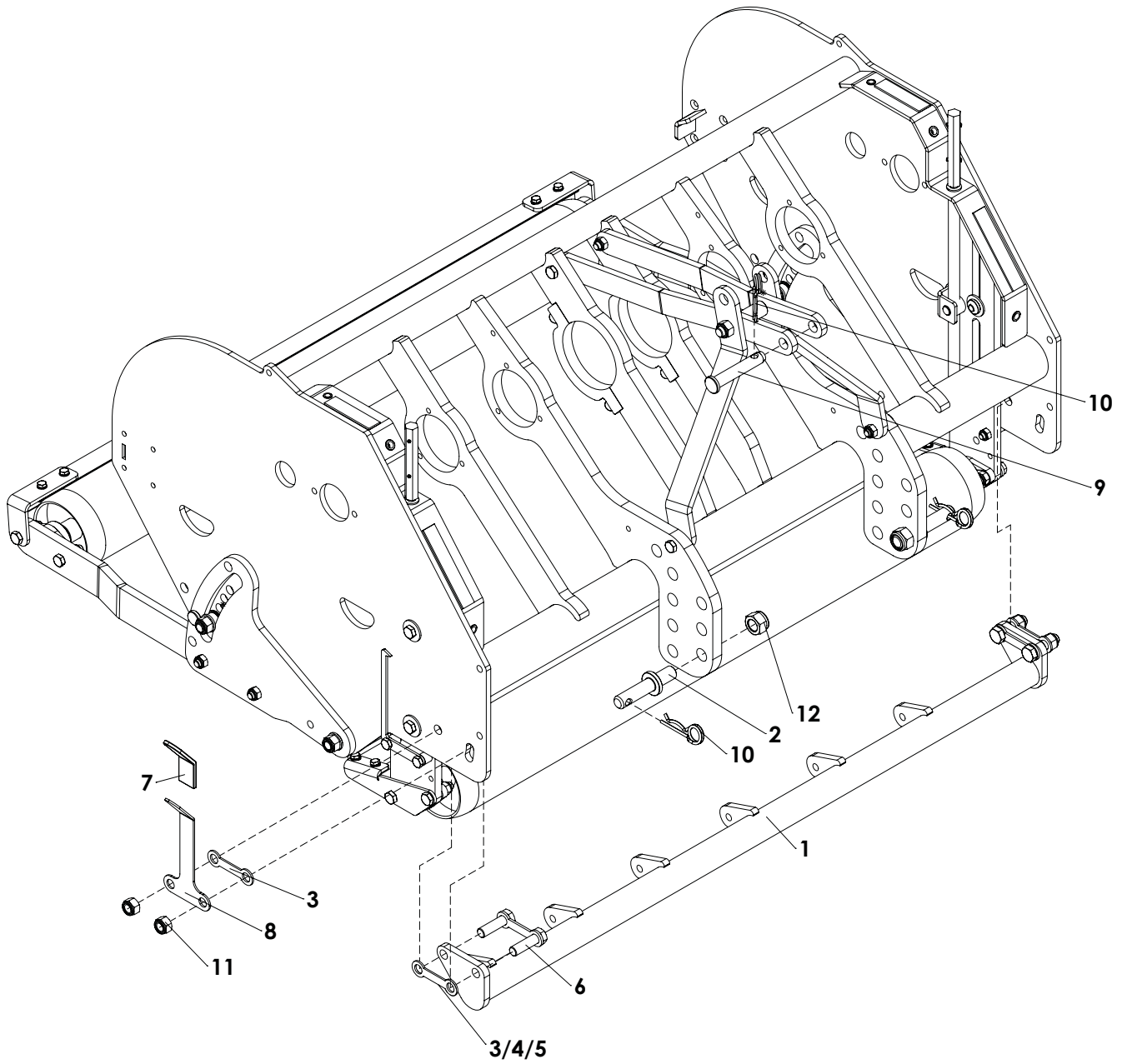

ITEM	PART NUMBER	DESCRIPTION	REMARKS	QUA
1	2381808	Central draw bar 7212		1
2	2490881	Bottom 3-Point Pin		2
3	2611527	Distance plate 3mm		4
4	2611528	Distance plate 2.5mm	Use to calibrate	2
5	2611530	Distance plate 2mm	Use to calibrate	2
6	426.161.020	Bolt assembly Central Bar		2
7	446.300.700	Cover for lever		1
8	468.032.120	Handle for angle adjustment		1
9	521.191.120	3-Point Pin		1
10	523.051.000	R-clip Round 5, DIN 11024		3
11	830.160.160	Self Lock Nut M16 - ISO 10511		4
12	830.220.220	Self Lock Nut M22 - ISO 10511		2

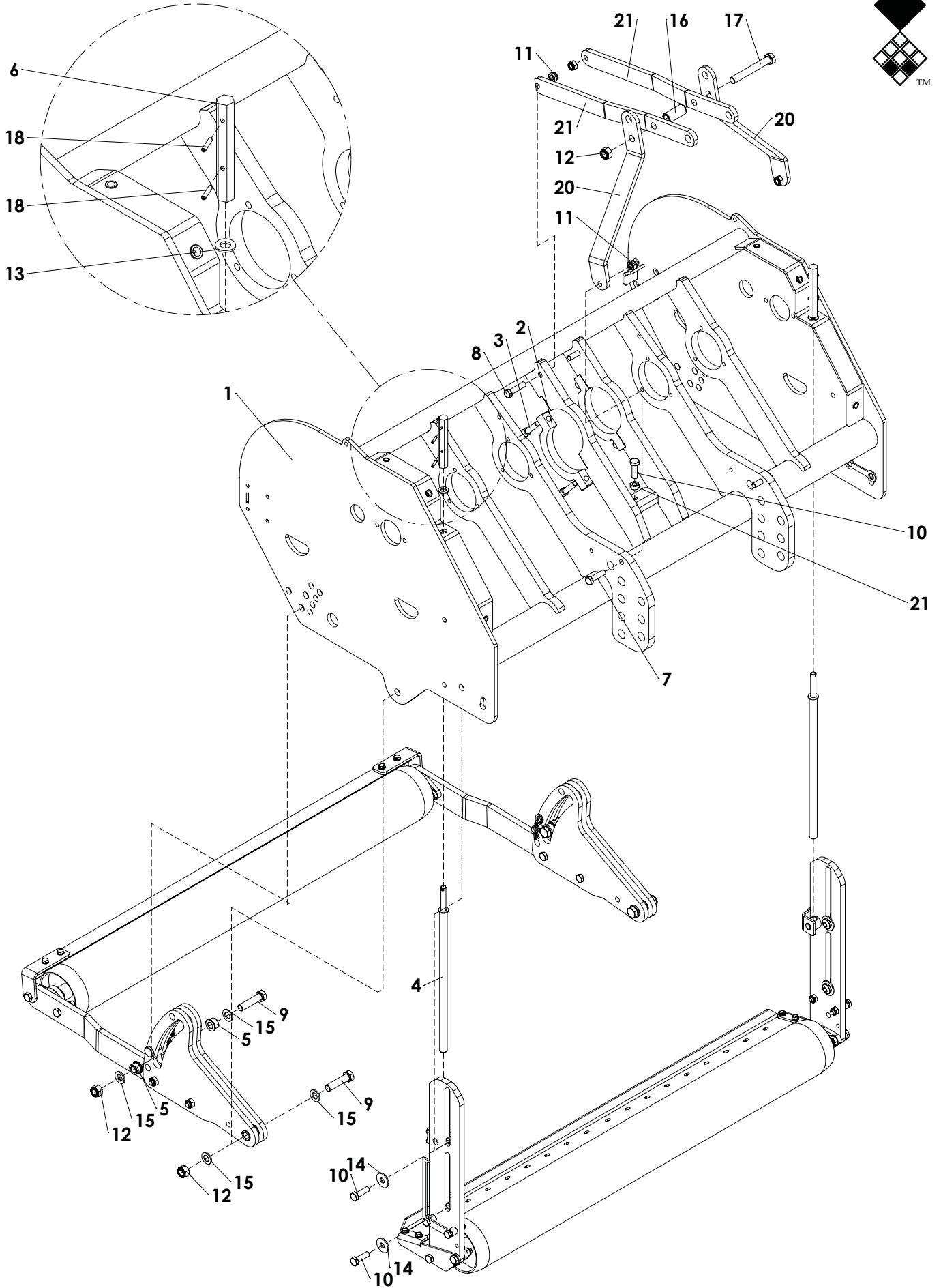

ITEM	PART NUMBER	DESCRIPTION	REMARKS	QUA
1	2305998	Frame 7212		1
2	2479102	Clamp		2
3	814.120.500	Bolt M12 x 50 - DIN 912		4
4	2692101	Spindle		2
5	404.160.160	Pivot bush		4
6	474.191.382	Spindle head		2
7	802.120.450	Bolt M12 x 45 ISO 4014 Class 10.9		2
8	802.120.500	Bolt M12 x 50 - ISO 4014 - 10.9		2
9	802.160.650	Bolt M16 x 65 - ISO 4014 - 10.9		4
10	804.120.400	Bolt M12 x 40 - ISO 4017		5
11	830.120.120	Self Lock Nut M12 - ISO 10511 Class 10		4
12	830.160.160	Self Lock Nut M16-ISO 10511 Class 10		5
13	864.120.030	Washer M12 - ISO 7089		2
14	864.120.031	Large washer M12 - DIN 9021		4
15	864.160.030	Washer M16 - ISO 7089		8
16	2611518	Distance bush		1
17	802.161.200	Bolt M16 x 120 - ISO 4014		1
18	878.050.240	Roll pin 5x24 - ISO 8752		4
19	2251384	Top linkage support strip		2
20	2251388	Top linkage strip		2
21	826.120.120	Nut M12 - DIN 934		1

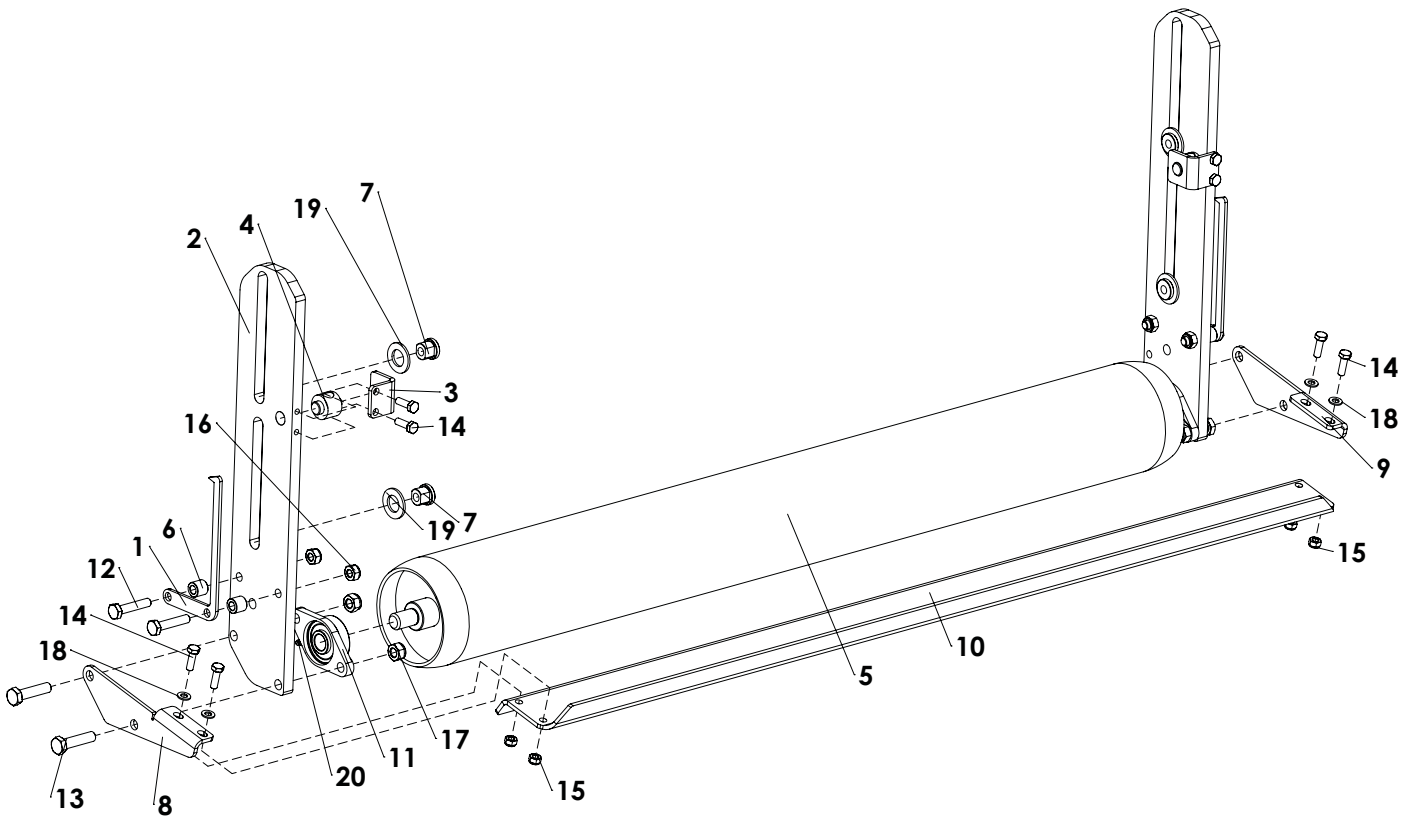

ITEM	PART NUMBER	DESCRIPTION	REMARKS	QUA
1	2281738	Height indicator		2
2	2281746	Front roller support		2
3	2282096	Spindle nut bracket		2
4	2282098	Spindle nut TR18x4		2
5	2343992	Roller 7212		1
6	406.180.170	Distance bush Ø18/Ø10.2 L=16.5		4
7	410.250.210	Sleeve bearing bush		4
8	464.051.940	Scraper support left		1
9	464.051.941	Scraper support right		1
10	468.059.130	Front scraper		1
11	742.200.330	Bearing UCFL 204		2
12	802.100.500	Bolt M10 x 50 - ISO 4014		4
13	802.120.500	Bolt M12 x 50 - ISO 4014		4
14	804.080.250	Bolt M8 x 25 - ISO 4017		8
15	830.080.080	Self Lock Nut M8 - ISO 10511		4
16	830.100.100	Self Lock Nut M10 - ISO 10511		4
17	830.120.120	Self Lock Nut M12 - ISO 10511		4
18	864.080.030	Washer M8 - ISO 7089		4
19	864.200.030	Washer M20 - ISO 7089		4
20	880.060.100	Grease nipple M6 DIN 71412A		2

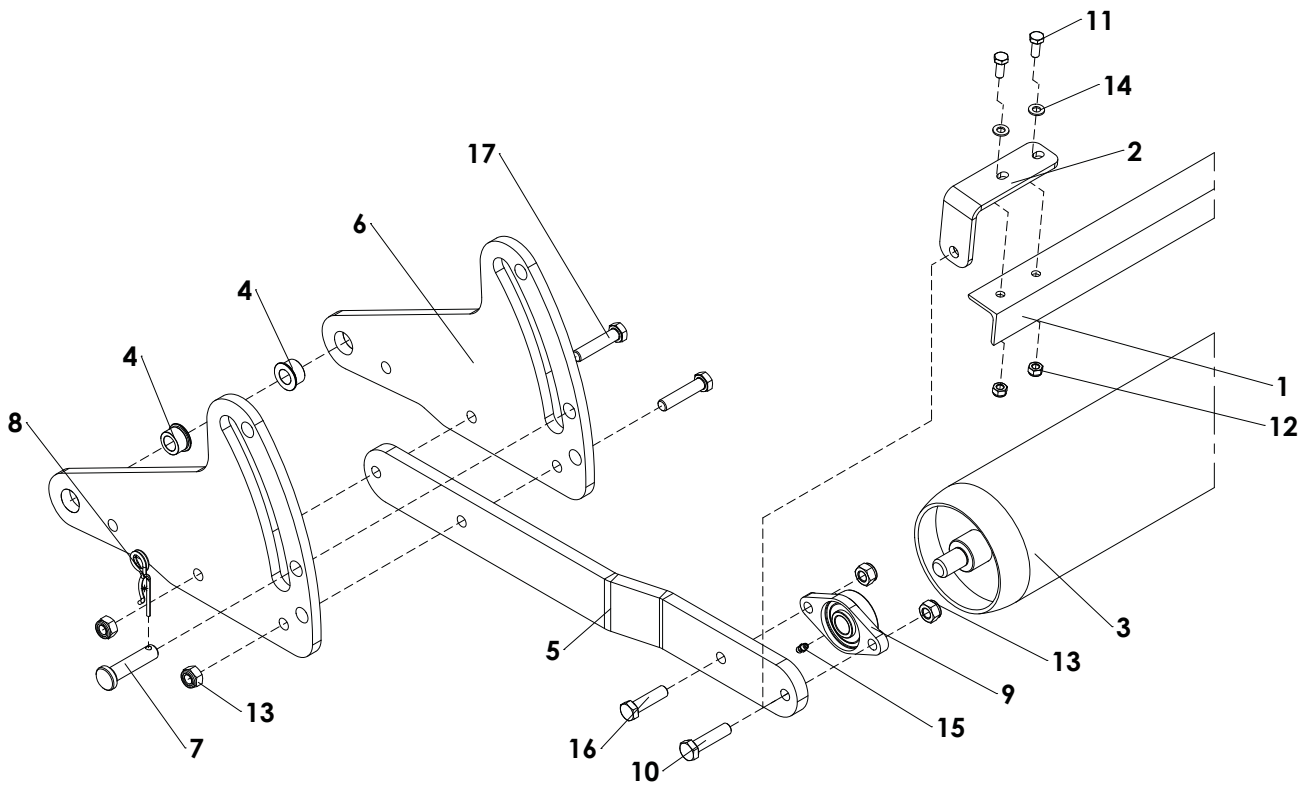

ITEM	PART NUMBER	DESCRIPTION	REMARKS	QUA
1	2281960	Rear roller scraper 7212		1
2	2281962	Rear roller scraper support 7212		2
3	2343992	Roller 7212		1
4	404.160.160	Pivot bush		4
5	464.155.920	Second rear roller support		2
6	468.123.700	Main Rear Roller support		4
7	521.160.510	Lock pin rear roller		2
8	523.030.750	R-Clip Round 3, DIN 11024		2
9	742.200.330	Bearing UCFL 204		2
10	802.120.500	Bolt M12 x 50 - ISO 4014		2
11	804.080.200	Bolt M8 x 20 - ISO 4017		4
12	830.080.080	Self Lock Nut M8 - ISO 10511		4
13	830.120.120	Self Lock Nut M12 - ISO 10511		8
14	864.080.030	Washer M8 - ISO 7089		4
15	880.060.100	Grease nipple M6 DIN 71412A		2
16	802.120.450	Bolt M12 x 45 - ISO 4014		2
17	802.120.550	Bolt M12 x 55 - ISO 4014 Class 8.8		4

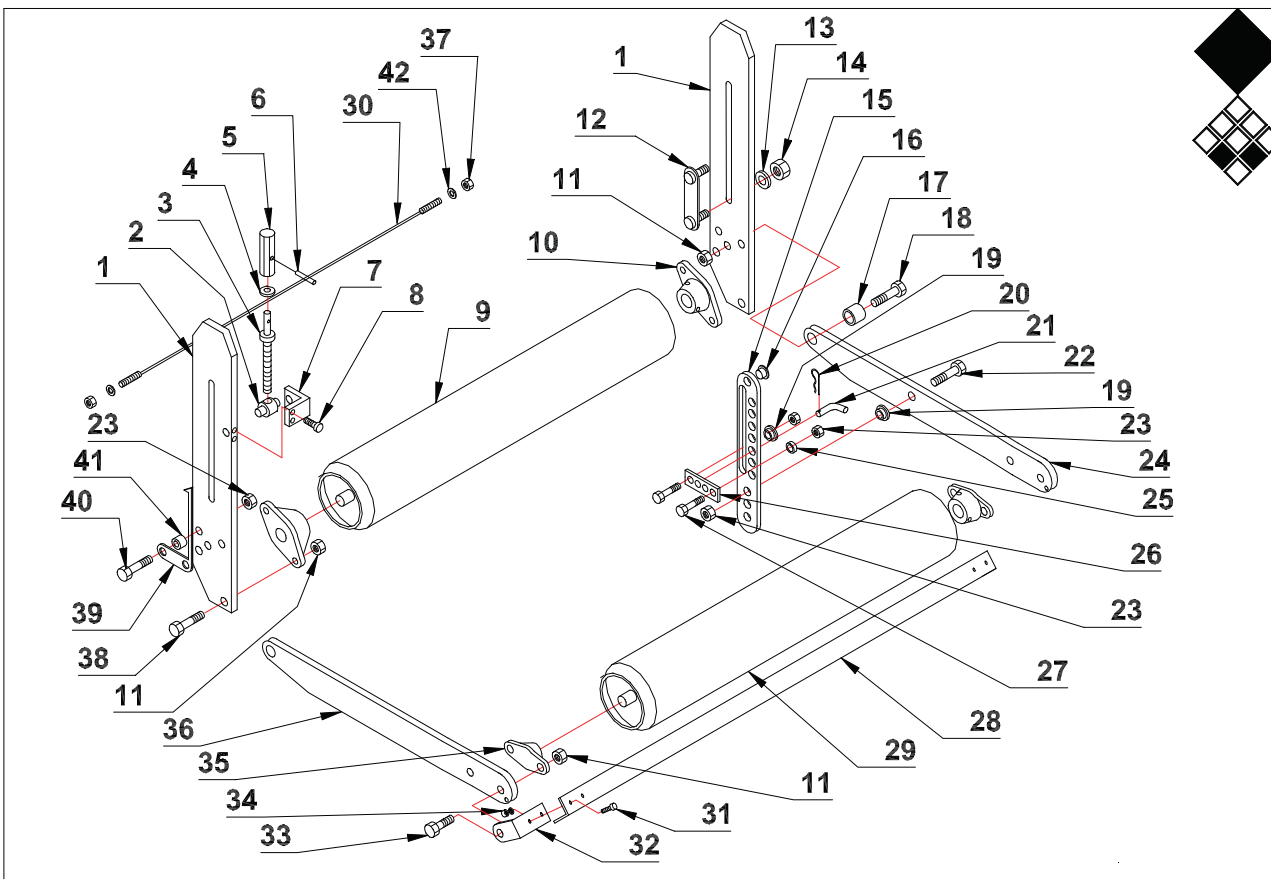

Redxim-Charterhouse Verti-Drain 7212 pag 09-1 code 0720

	PART #	DESCRIPTION	REMARKS	QUA
1	2281746	Front roller support 7212		2
2	2282098	Spindle nut		2
3	2692101	Spindle		2
4	4910120	Washer		2
5	2282094	Spindle head		2
6	4311020	Roll pin		2
7	2282096	Spindle nut bracket		2
8	4001432	Bolt M8 x 25		4
9	2343992	Front roller 7212		1
10	4833990	Front roller bearing		2
11	4122600	Self lock nut M12		10
12	2282092	Bolt assembly		2
13	4910160	Washer M 16		4
14	4123800	Self lock nut M16		4
15	2281745	Rear roller support guide		2
16	4972550	Plastic stop		2
17	2611514	Pivot bush rear roller support		2
18	4001866	Bolt M12 x 50		2
19	2611510	Guide bush		4
20	4397000	R pin		2
21	2499114	Lock pin rear roller support guide		2
22	4001680	Bolt M10 x 45		2
23	4122000	Self lock nut M 10		8
24	2281741	Rear roller support right		1
25	2611516	Distance bush		2
26	2281744	Plate		2
27	4001680	Bolt M10 x 45		4
28	2281960	Rear roller scraper profile		1
29	2343992	Rear roller 7212		1
30	2281737	Wire scraper		1
31	4001424	Bolt M8 x 20		4
32	2281962	Bracket support for rear roller scraper		2
33	4001866	Bolt M 12 x 50		4
34	4121400	Self lock nut M8		4
35	4833990	Rear roller bearing 7212		2
36	2281743	Rear roller support left		1
37	4100800	Nut M6		4
38	4001858	Bolt M12 x 45		4
39	2281738	Height indicator		2
40	4001680	Bolt M10 x 45		4
41	2611516	Distance bush		4
42	4910060	Washer		2

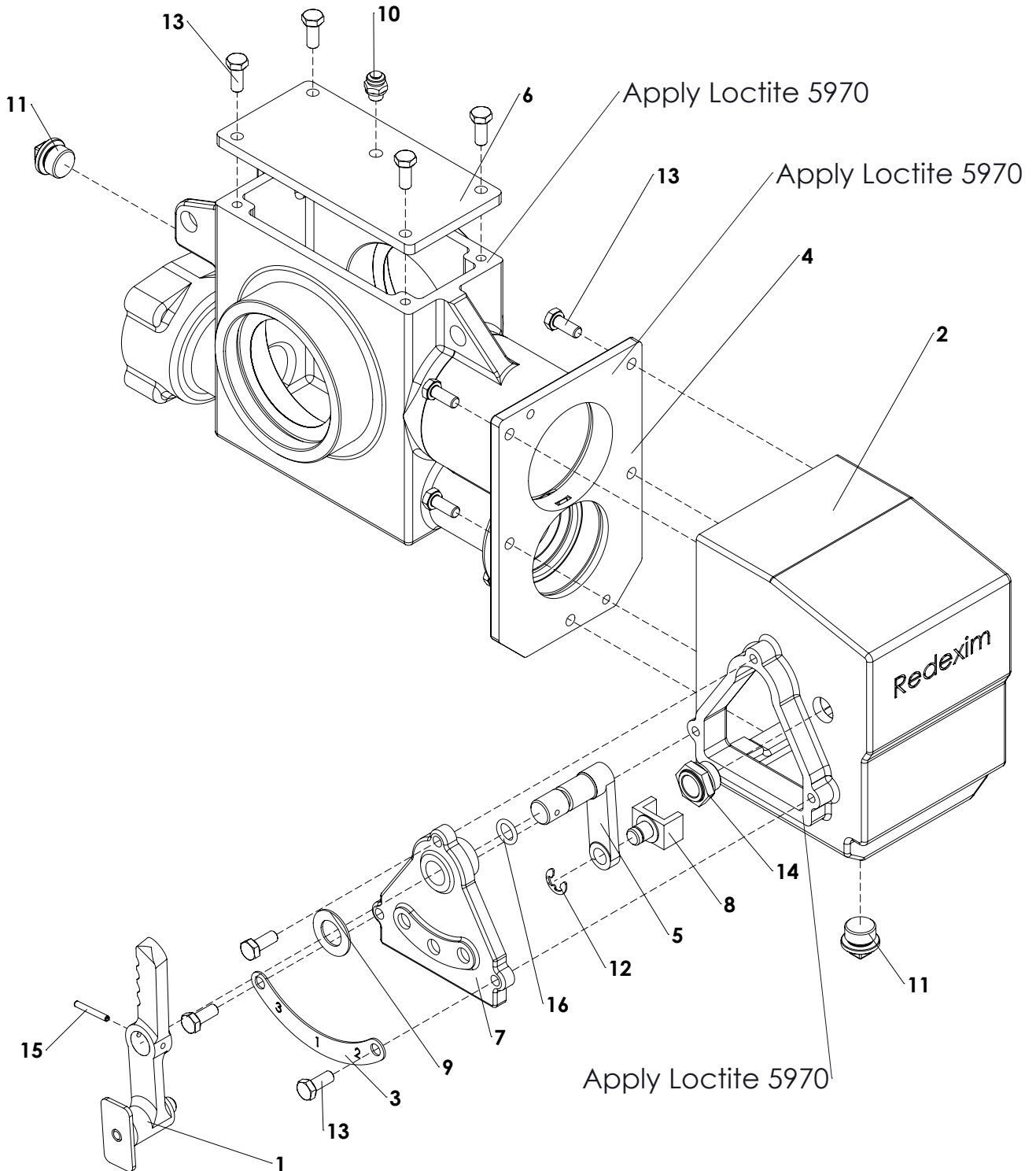

ITEM	PART NUMBER	DESCRIPTION	REMARKS	QUA
1	1991400	Gear shifter		1
2	2401204	Rear part gearbox		1
3	2281739	Gear indicator plate		1
4	2401203	Front part gearbox		1
5	2469200	Lever with pin		1
6	2471220	Top plate gearbox		1
7	2471241	Shield		1
8	2779976	Fork		1
9	2894039	Plastic washer 19x34x1.5		1
10	4067008	Breather gearbox		1
11	4561000	Tap 1/2"		2
12	4752009	Seeger RS9		1
13	804.080.200	Bolt M8 x 20 - ISO 4017		12
14	820.210.180	Level / fill glass		1
15	878.040.300	Roll Pin 4 x 30 - ISO 8752		1
16	766.130.030	O-ring Ø12.5x3		1
		Use gear oil 80W90		3.0 liter
	1441203-67	Gearbox complete		

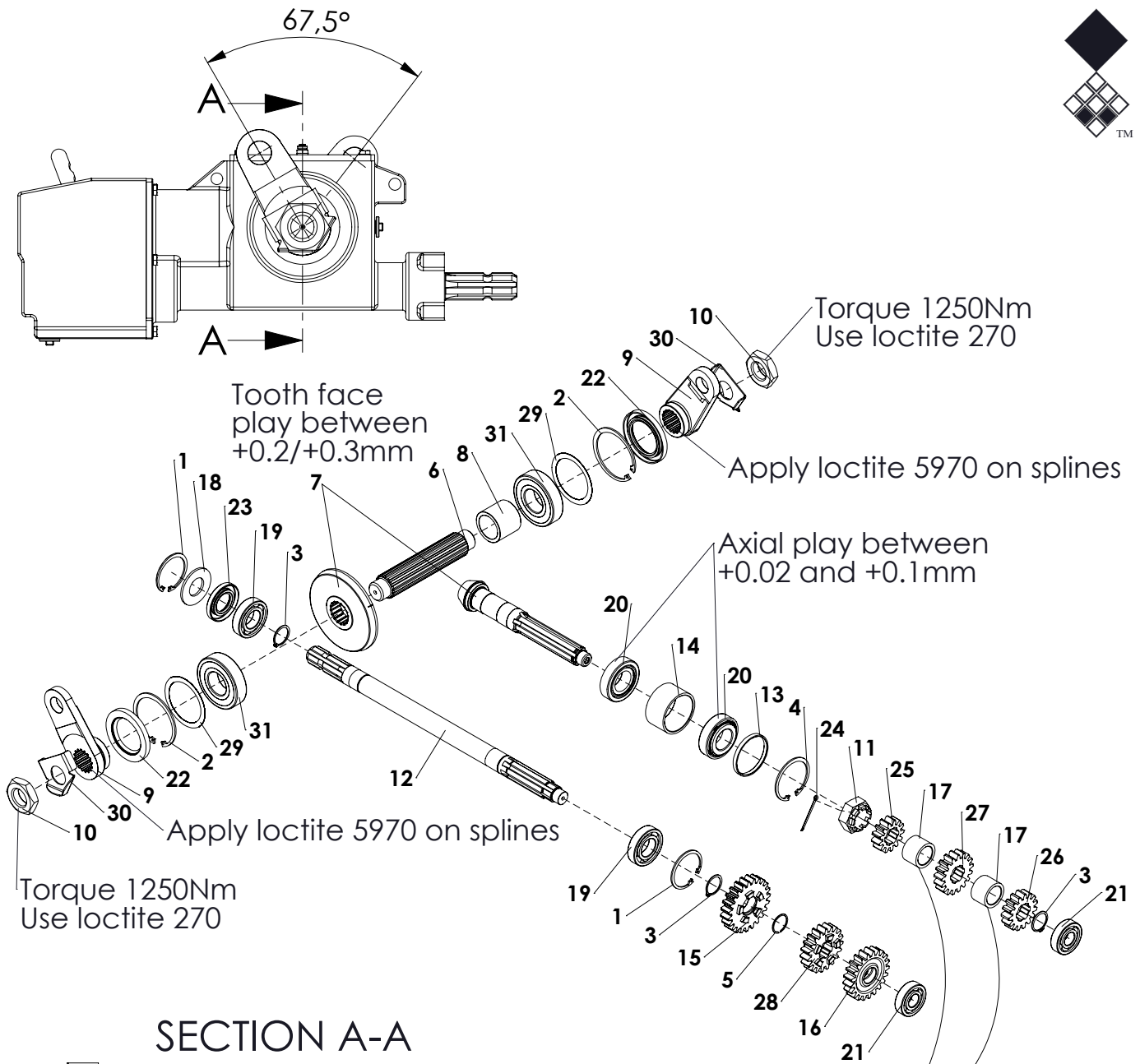

SECTION A-A

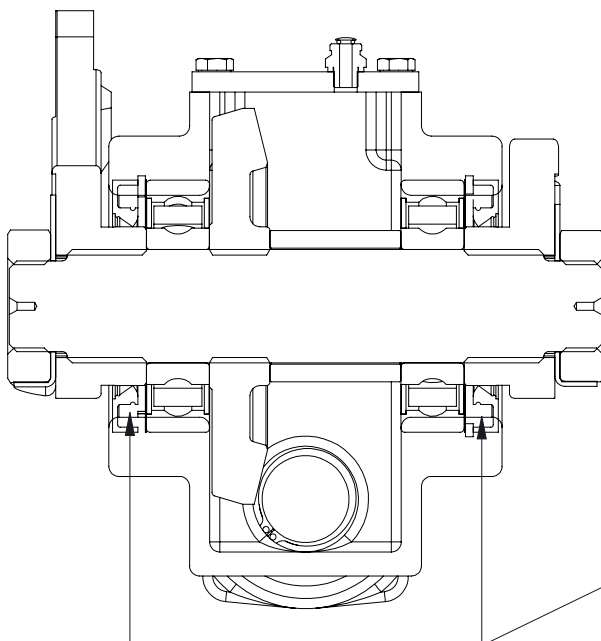

Identification item 17:
 L=34mm / 1.34 inch => 2611212
 L=32mm / 1.26 inch => 406.360.320

Fill area between seal and bearing complete with a NLGI 2-3 bearing grease.
 Also apply grease between shaft and seal before assembly.

ITEM	PART NUMBER	DESCRIPTION	REMARKS	QUA
1	872.072.250	Circlip D=72 - DIN 472		2
2	872.100.300	Circlip D=100 - DIN 472		2
3	870.035.160	Circlip d=35 - DIN 471		3
4	872.080.250	Circlip D=80 - DIN 472		1
5	4755035	Seeger SW35		1
6	2462010	Main shaft		1
7	2526400	Crownwheel and Pinion	Contains crownwheel and pinion and 2x distance bush item 17 to be applied as a set.	1
8	2613000	Bush		1
9	2447200	Splined arm		2
10	4109200	Nut M36x3		2
11	4135000	Nut		1
12	2460400	Input shaft		1
13	2611208	Distance bush		1
14	2611200	Distance bush		1
15	2504481	Gear z23		1
16	2504467	Gearwheel Z=21		1
17	2611212	Distance bush	Check length L=34mm / 1.34 inch	2
	406.360.320	Distance bush	Check length L=32mm / 1.26 inch	2
18	2661256	Washer		1
19	711.350.170	Bearing 6207		2
20	4810470	Bearing 32208		2
21	4816750	Bearing 6305		2
22	4409160	Oil seal 63x100x10		2
23	4406420	Oil seal 35x72x10		1
24	882.030.560	Cotter Pin 3.2 x 56 - DIN 94		1
25	432.200.640	Gearwheel Z=13		1
26	432.200.720	Gearwheel Z=15		1
27	432.200.810	Gearwheel Z=17		1
28	432.320.890	Gearwheel Z=19		1
29	869.100.001	Set of shims 80x100 4x0.1 2x0.3		1
30	2281800	Lock plate		2
31	713.450.250	Bearing 6309-2RS		2

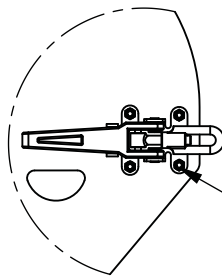
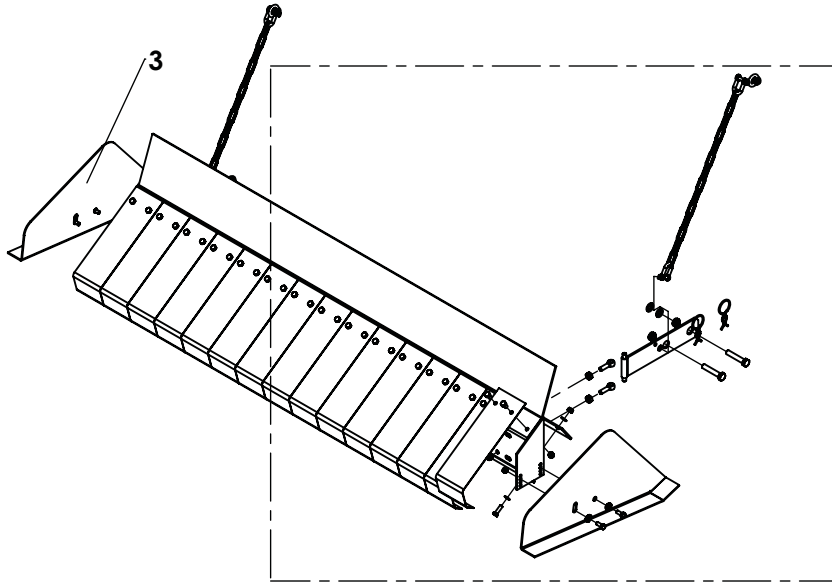

Remove nut and mount lifting eye (21)

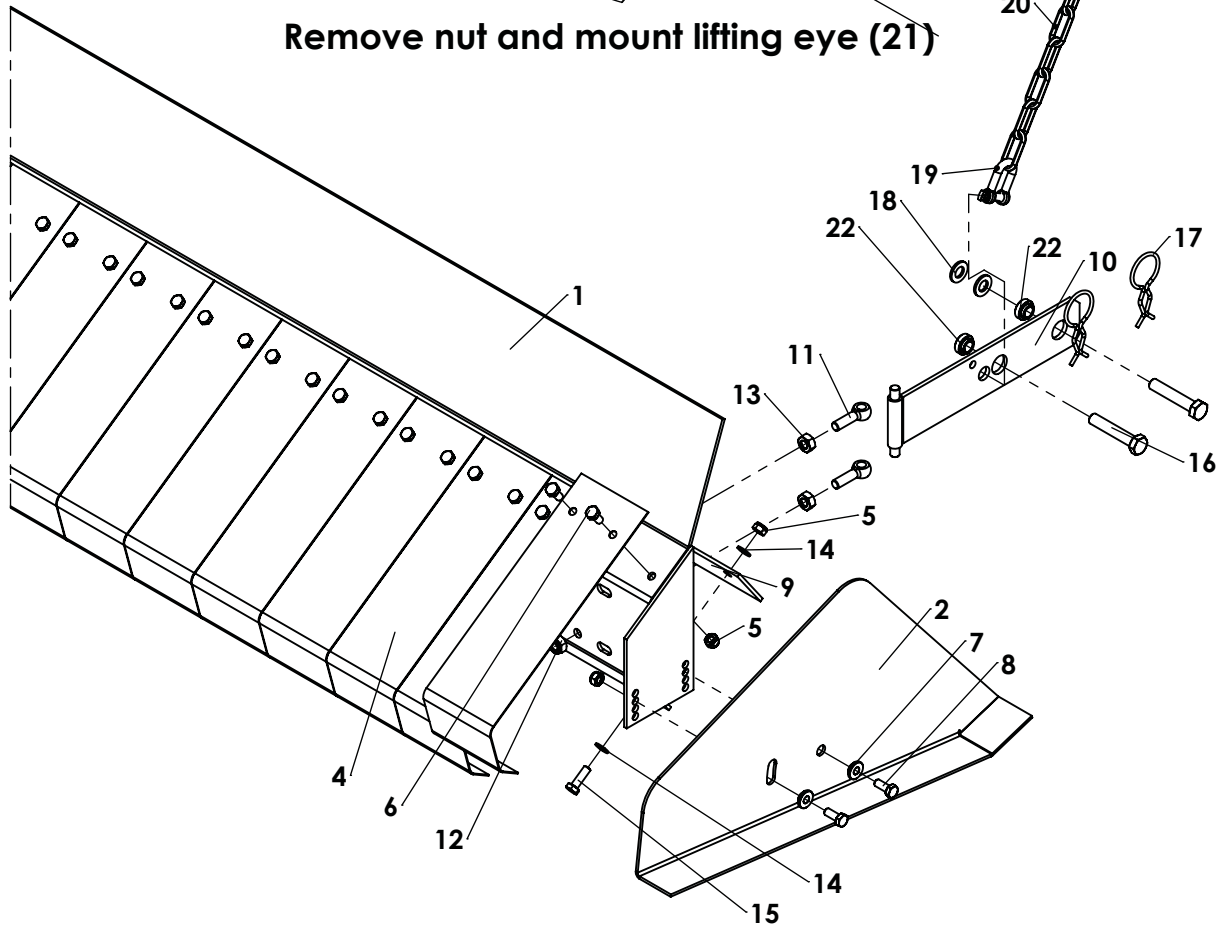

ITEM	PART NUMBER	DESCRIPTION	REMARKS	QUA
1	470.049.156	Frame beam 7212		1
2	468.035.420	Right side plate		1
3	468.035.422	Left side plate		1
4	468.013.100	Blade spring		15
5	830.080.080	Self Lock Nut M8 - ISO 10511		43
6	804.080.160	Bolt M8 x 16 - ISO 4017		30
7	404.080.700	Distance bush		4
8	804.080.200	Bolt M8 x 20 - ISO 4017		4
9	446.049.151	Rubber strip		1
10	470.052.800	Support arm		2
11	822.100.400	Eye bolt M10 x 40 DIN 444 - LB		4
12	830.100.100	Self Lock Nut M10 - ISO 10511		4
13	826.100.100	Nut M10 - DIN 934		4
14	864.080.030	Washer M8 - ISO 7089		18
15	804.080.250	Bolt M8 x 25 - ISO 4017		9
16	802.120.650	Bolt M12 x 65 - ISO 4014		4
17	523.030.752	Special R-clip d3		4
18	864.120.030	Washer M12 - ISO 7089		4
19	846.080.241	D-Shackle D8		4
20	846.064.300	Chain d=5mm l=0.5m		2
21	822.080.360	Lifting Eye Nut M8 - DIN 582		2
22	404.120.100	Distance bush		4
	9100080	Core Collector 7212 complete		1



Remove nut and mount lifting eye (17)

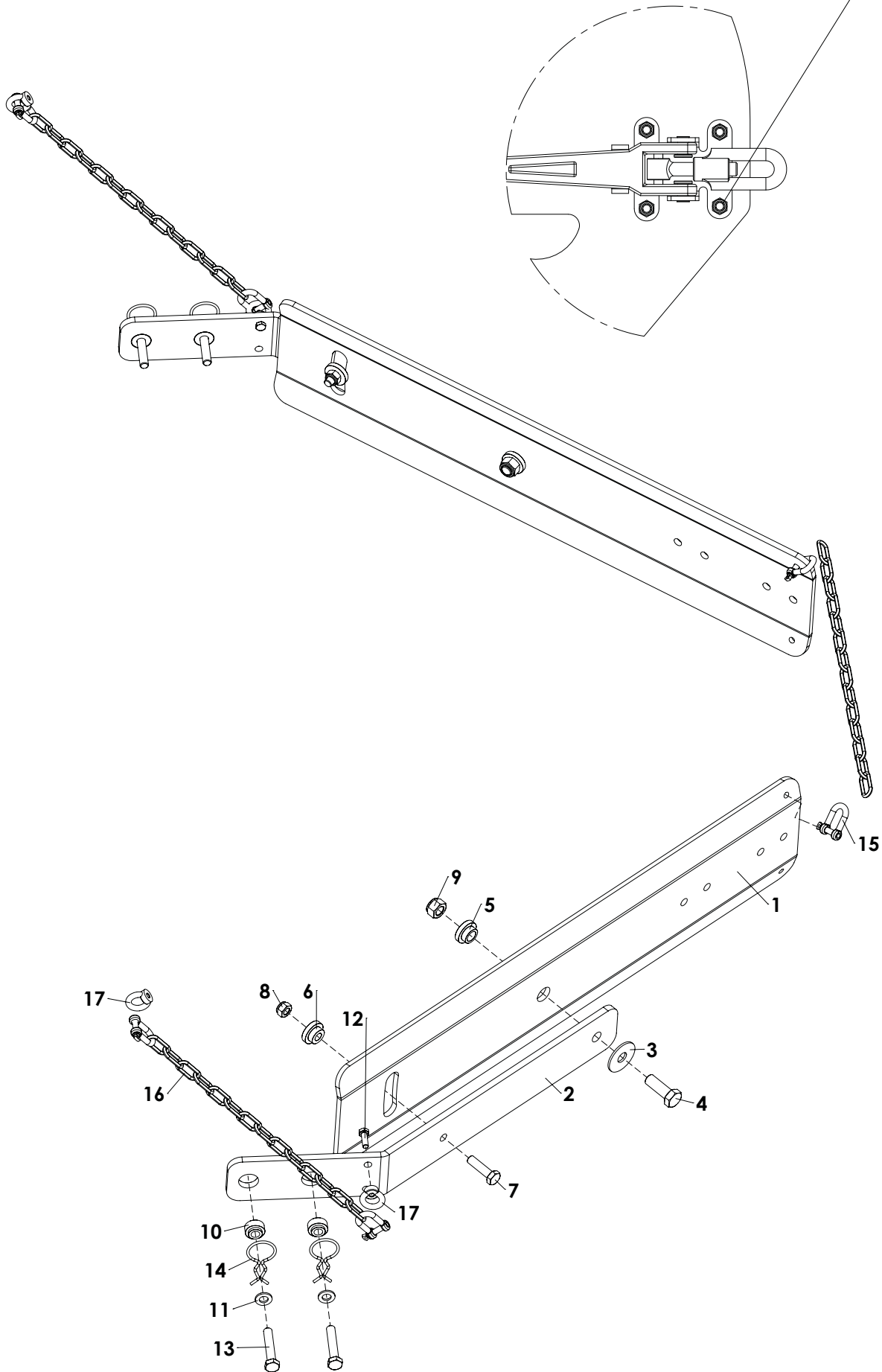

ITEM	PART NUMBER	DESCRIPTION	REMARKS	QUA
1	468.089.000	Windrow plate		2
2	464.106.352	Windrow support		2
3	864.160.031	Large washer M16 - DIN 9021		2
4	804.160.450	Bolt M16 x 45 - ISO 4017		2
5	406.160.150	Distance bush		2
6	406.130.150	Distance bush		2
7	804.120.450	Bolt M12 x 45 - ISO 4017		2
8	830.120.120	Self Lock Nut M12 - ISO 10511		2
9	830.160.160	Self Lock Nut M16 - ISO 10511		2
10	406.120.150	Distance bush		4
11	864.120.030	Washer M12 - ISO 7089		4
12	804.080.250	Bolt M8 x 25 - ISO 4017		2
13	802.120.650	Bolt M12 x 65 - ISO 4014		4
14	523.030.752	Special R-clip d3		4
15	846.080.241	D-Shackle D8		6
16	846.064.300	Chain, 12 chackles (d=5mm l=0.5m)		3
17	822.080.360	Lifting Eye Nut M8 - DIN 582		4
	211.721.016	Windrow kit 7212/7215 complete		

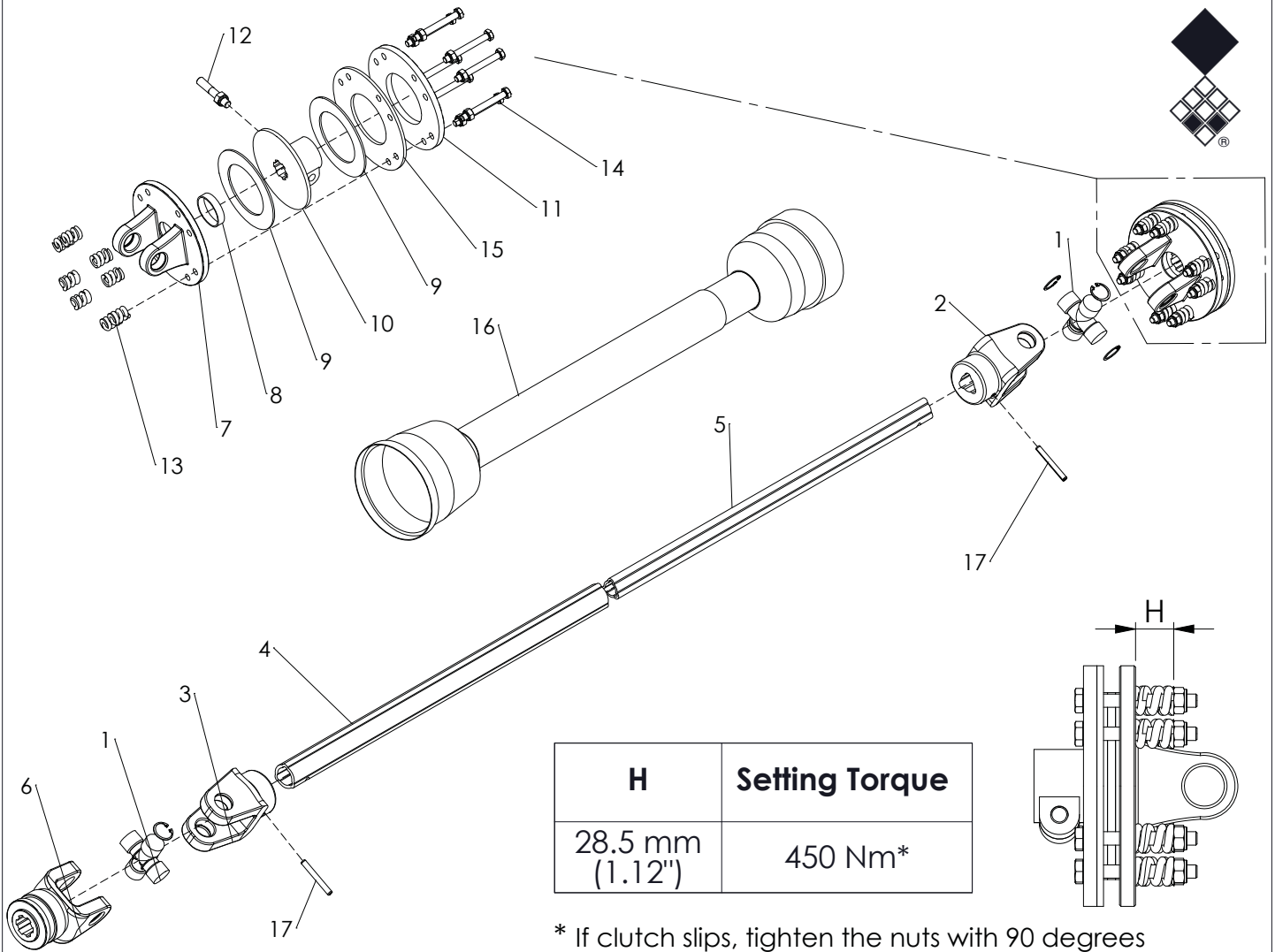

H	Setting Torque
28.5 mm (1.12")	450 Nm*

* If clutch slips, tighten the nuts with 90 degrees at a time to a maximum of 27.5mm (1.08") = +150Nm

ALWAYS deburr parts when cut
MEASURE correct length of PTO first
MAINTAIN slipclutch every month
NEVER USE PTO over 30 degrees
SLIPCLUTCH always on machine side

ITEM	PART NUMBER	DESCRIPTION	REMARKS	QUA
1	BEN PT140106	Universal joint assembled		2
2	BEN PT148813	Inner tube yoke		1
3	BEN PT143860	Outer tube yoke		1
4	BEN PT150516	Tubing cut to size	Cut to correct length	1
5	BEN PT150544	Tubing cut to size	Cut to correct length	1
6	BEN PT140106	End yoke with quick lock		1
7	BEN F1L04	Flange yoke		1
8	BEN F060	Bush		1
9	BEN F030/S	Lining ring		2
10	BEN F138	Hub		1
11	BEN F1180	Pressure plate		1
12	BEN 90938	Conic bolt and nut		1
13	BEN F0110	Spring		8
14	BEN F10085	Bolt and nut		8
15	BEN F070	Inner plate		1
16	BEN PT170005	Safety guard group	Cut to correct length	1
17	190000014	Roll Pin 8 x 65		2
	611.409.100	PTO shaft type T-40 tl 910		
	611.405.100	PTO shaft type T-40 tl 510		

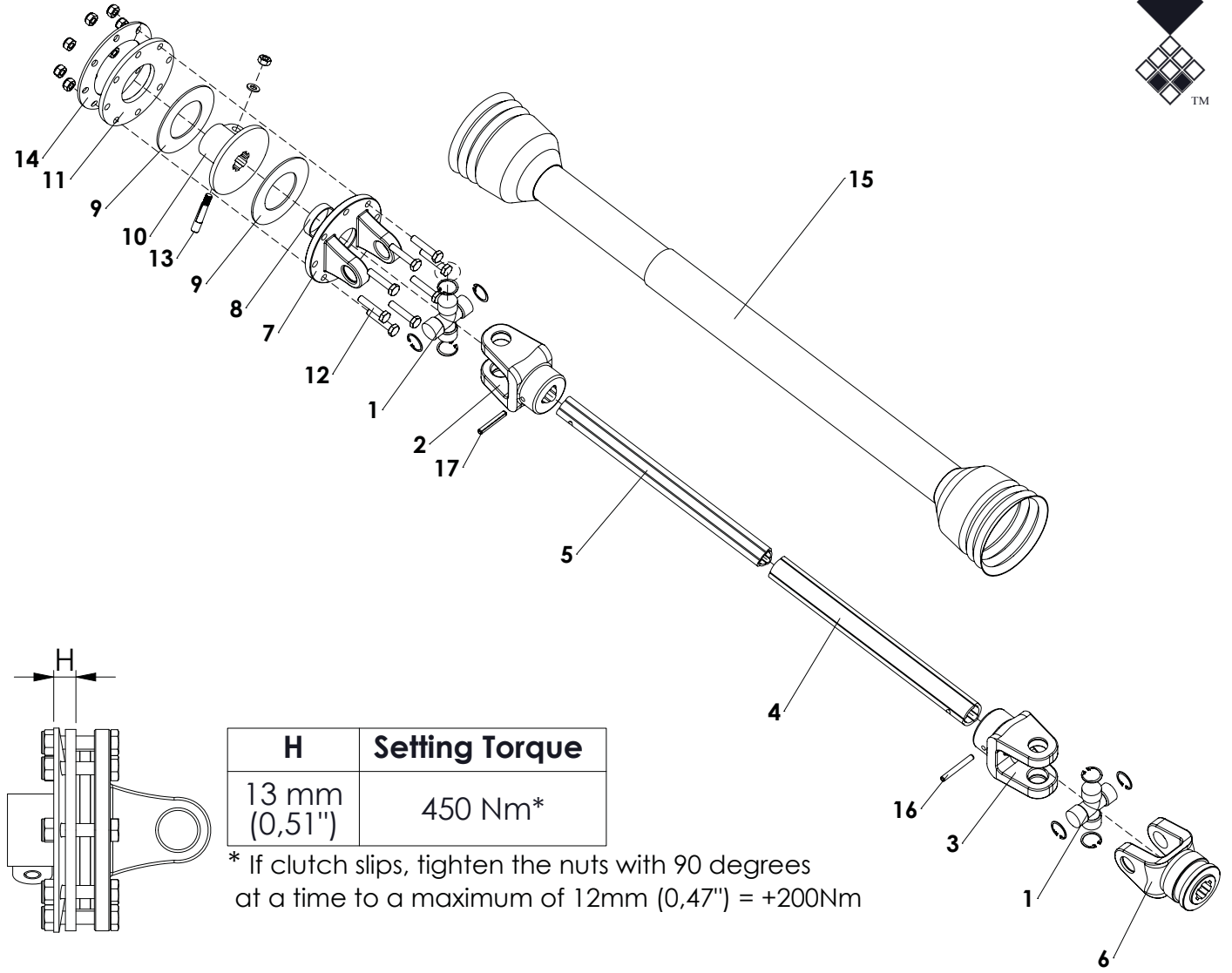

H	Setting Torque
13 mm (0,51")	450 Nm*

* If clutch slips, tighten the nuts with 90 degrees at a time to a maximum of 12mm (0,47") = +200Nm

ALWAYS deburr parts when cut
MEASURE correct length of PTO first
MAINTAIN slipclutch every month
NEVER USE PTO over 30 degrees
SLIPCLUTCH always on machine side

ITEM	PART NUMBER	DESCRIPTION	REMARKS	QUA
1	180014130	Cross and 4x circlip kit		2
2	1510140071	Inner tube yoke type 40		1
3	1410140061	Outer tube yoke type 40		1
4	1521406620700	T40-series Outer tube	Cut to correct length	1
5	153140519	T40-series Inner tube	Cut to correct length	1
6	1410244301	Complete collar yoke type 40		1
7	1510143791	Flanged yoke T40		1
8	180015020	Bush		1
9	180014019	Lining ring		2
10	1510148401	Hub T40		1
11	1800175681	Pressure plate		1
12	165000858	Bolt & nut M10 x 1,5 x 50		8
13	165000588	Tapered Pin 1 3/8" kit	Retighten every 40 hours	1
14	180017425	Belleville spring		1
15	1423400167451	Complete guard 40-series	Cut to correct length	1
16	190000014	Roll Pin 8 x 65		1
17	190000012	Roll Pin 8 x 55		1
	400510	Complete PTO T40		
	400910	Complete PTO T40 for boggy		

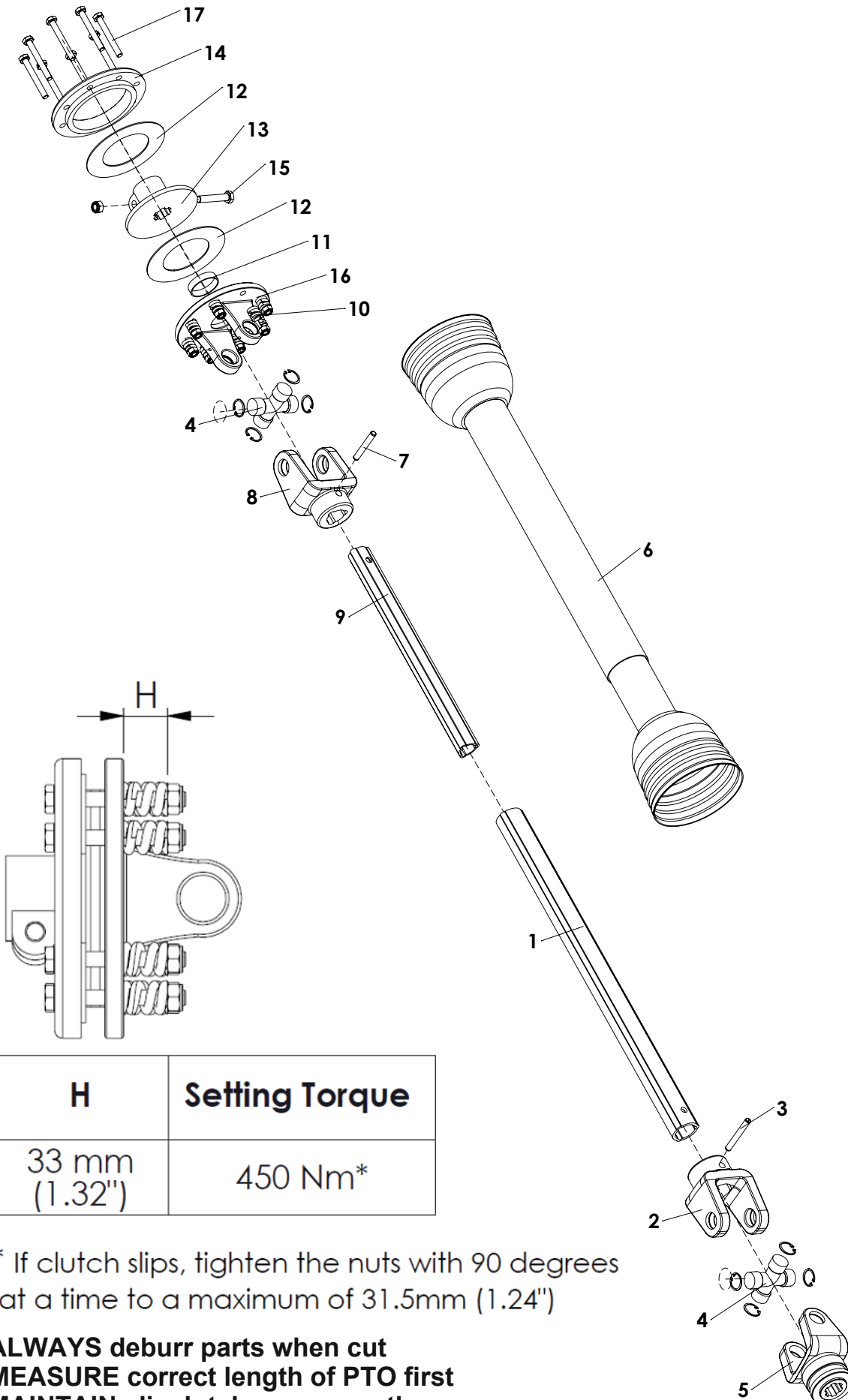







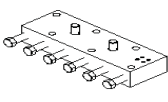
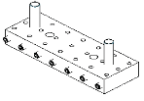
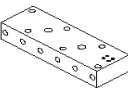

H	Setting Torque
33 mm (1.32")	450 Nm*

* If clutch slips, tighten the nuts with 90 degrees at a time to a maximum of 31.5mm (1.24")

ALWAYS deburr parts when cut
MEASURE correct length of PTO first
MAINTAIN slipclutch every month
NEVER USE PTO over 30 degrees
SLIPCLUTCH always on machine side

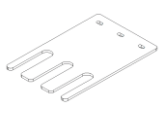
ITEM	PART NUMBER	DESCRIPTION	REMARKS	QUA
1	152140207	Outer tube		1
2	151014006	Outer tube yoke		1
3	190000014	Outer roll pin		1
4	180014130	Cross and 4x circlip kit		2
5	141024430	Complete collar yoke		1
6	1422400307430	Complete guard	Cut to correct length	1
7	190000012	Inner roll pin		1
8	151004007	Inner tube yoke		1
9	153140107	Inner tube		1
10	180014022	Spring		8
11	180015020	Bush		1
12	180014019	Lining ring		2
13	151014018	Hub		1
14	180014020	Pressure plate		1
15	165000502	Bolt and Nut	Retighten every 40 hours	1
16	151014017	Flanged yoke		1
17	165000501	Bolt and nut		8
	400510	Complete PTO		
		ALWAYS deburr parts when cut		
		MEASURE correct length of PTO first		
		MAINTAIN slipclutch every month		
		NEVER USE PTO over 30 degrees angle		
		SLIPCLUTCH always on machine side		

Adapter							7212	
		Tine Size (mm)	Tine Size (inch)	Part #			Qua	
	J	5	3/16	314.205.043			18	
	K	8	5/16	314.208.043			18	
Adapter							7212	
		Tine Size (mm)	Tine Size (inch)	Part #			Qua	
	L	18	3/4	2451800				
Multi-tine block complete WO tines							7212	
		Tine Size (mm)	Tine Size (inch)	Part #			Qua	
		8mm (6 tines)	5/16	9990206	Combination of:	M-U	Tines: A1-A2-A3-A4-A5 6 (36 tines)	
		Tines:						
	A1	8 x 150	5/16 x 6	311.108.150	Solid tine			
	A2	8 x 175	5/16 x 7	9990056	Solid tine			
	A3	10 x 6 x 80	3/8 x 1/4 x 3	311.210.080	Hollow tine			
	A4	10 x 6 x 125	3/8 x 1/4 x 5	311.210.127	Hollow tine			
A5	12 x 90	1/2 x 3 1/2	9990020	Cross tine				
Multi-tine block mini needles complete WO tines							7212	
		Tine Size (mm)	Tine Size (inch)	Part #			Qua	
		5	3/16	314.425.170	Combination off:	Q-V-X	Tines: B1 6 (126 tines)	
		Tines:						
B1	5 x 125	3/16 x 5	311.105.125	Needle tine				
Multi-tine block empty							7212	
		Tine Size (mm)	Tine Size (inch)	Part #			Qua	
	M	8mm (6 tines)	5/16	9990201			6	
Multi-tine block mini needles empty							7212	
		Tine Size (mm)	Tine Size (inch)	Part #			Qua	
	Q	5 (21 tines)	3/16	480.251.740			6	
Tine lock bolt							7212	
		Size (mm)		Part #			Qua	
	U	10x35		4001675			36	
Set screw							7212	
		Size (mm)		Part #			Qua	
	V	8x8		818.080.080			126	
Stud							7212	
		Size (mm)		Part #			Qua	
	X	12x60		9990212D			12	
Turf hold down fingers							7212	
		Part name					Part #	Qua
		Turf hold down finger 12mm					311.506.186	6
		Turf hold down finger 18mm					311.506.188	6
Turf hold down kit							7212	
		Part name					Part #	Qua
		THD kit complete 12mm					211.721.014	1
		THD kit complete 18mm					211.721.012	1

