

BLECAVATOR 145-210

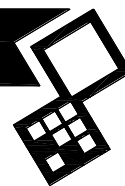

Version: 2425

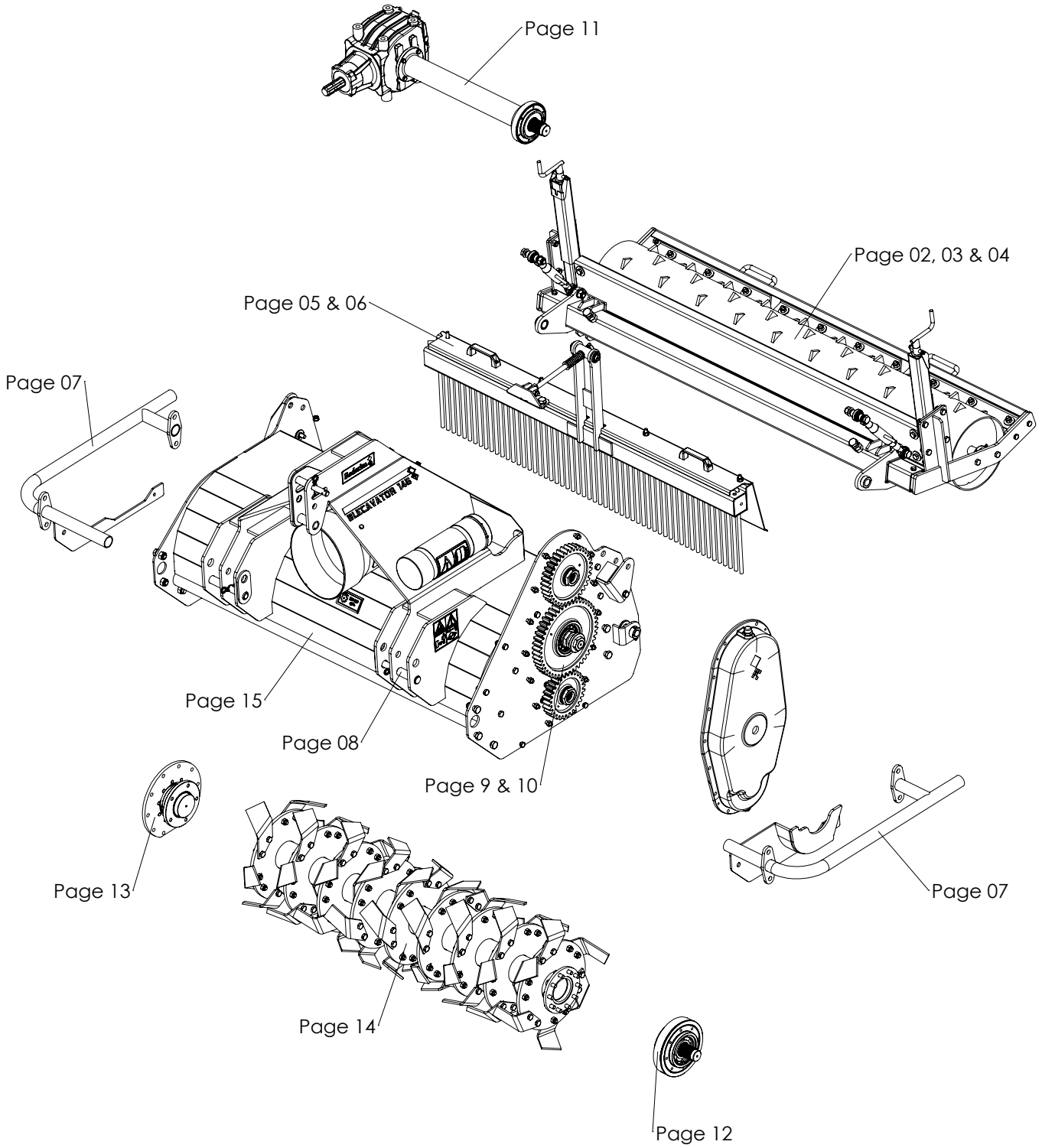

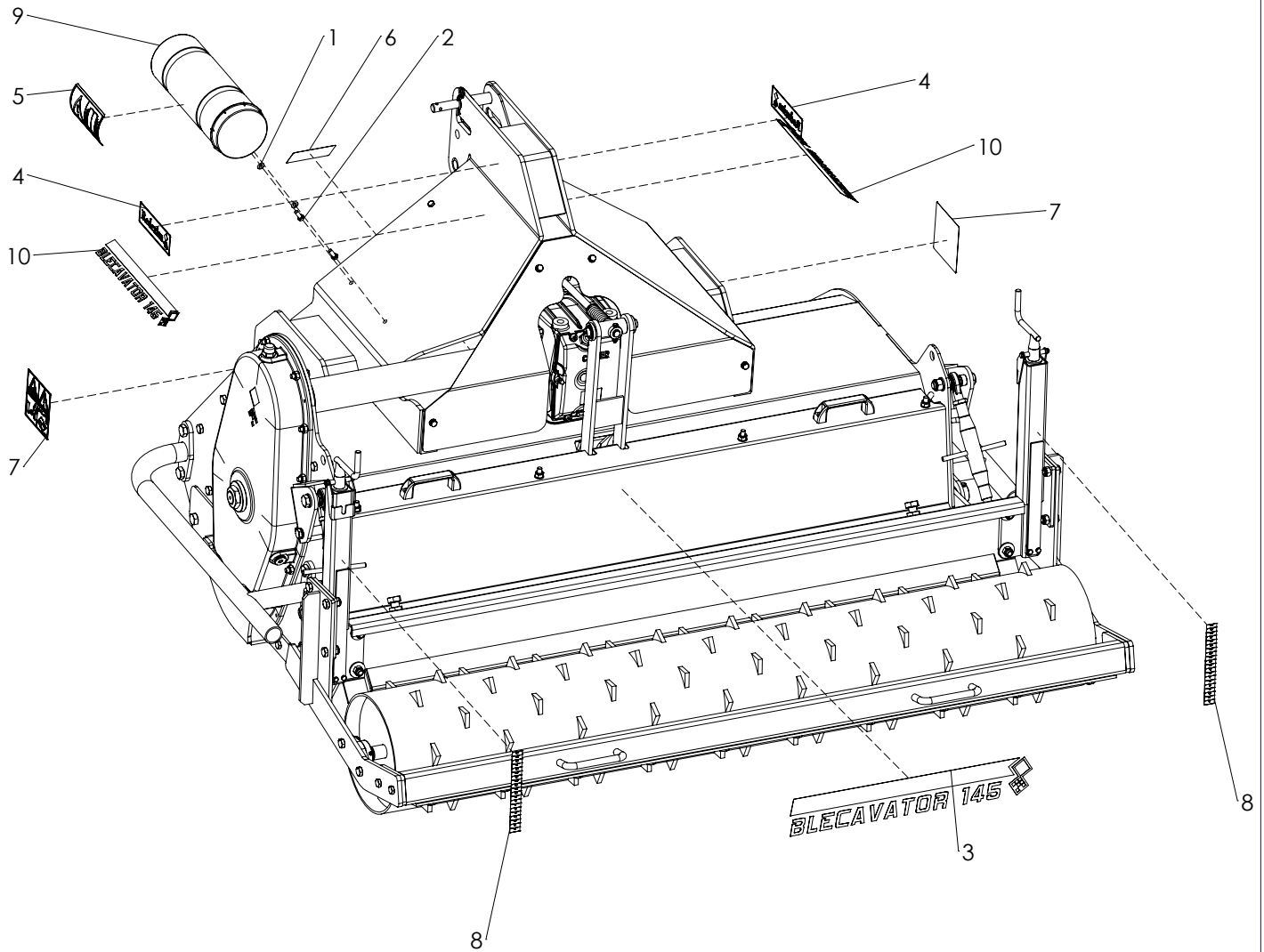

ITEM	PART NUMBER	DESCRIPTION	REMARKS	QUA 145	QUA 210
1	864.080.030	Washer M8 - ISO 7089		6	6
2	804.080.200	Bolt M8 x 20 - ISO 4017		6	6
3	952.260.311	Label Blecavator 145 Large		1	0
	952.260.309	Label Blecavator 210 Large		0	1
4	900.260.401	Logo Label		2	2
5	900.280.402	Safety decall manual		1	1
6	900.260.422	Decal PTO 350 540		1	1
7	921.280.402	Safety decall VS		2	2
8	900.260.414	Decal Ruler		2	2
9	444.803.100	Toolbox Complete		1	1
10	952.260.307	Label Blecavator 145		2	0
	952.260.305	Label Blecavator 210		0	2

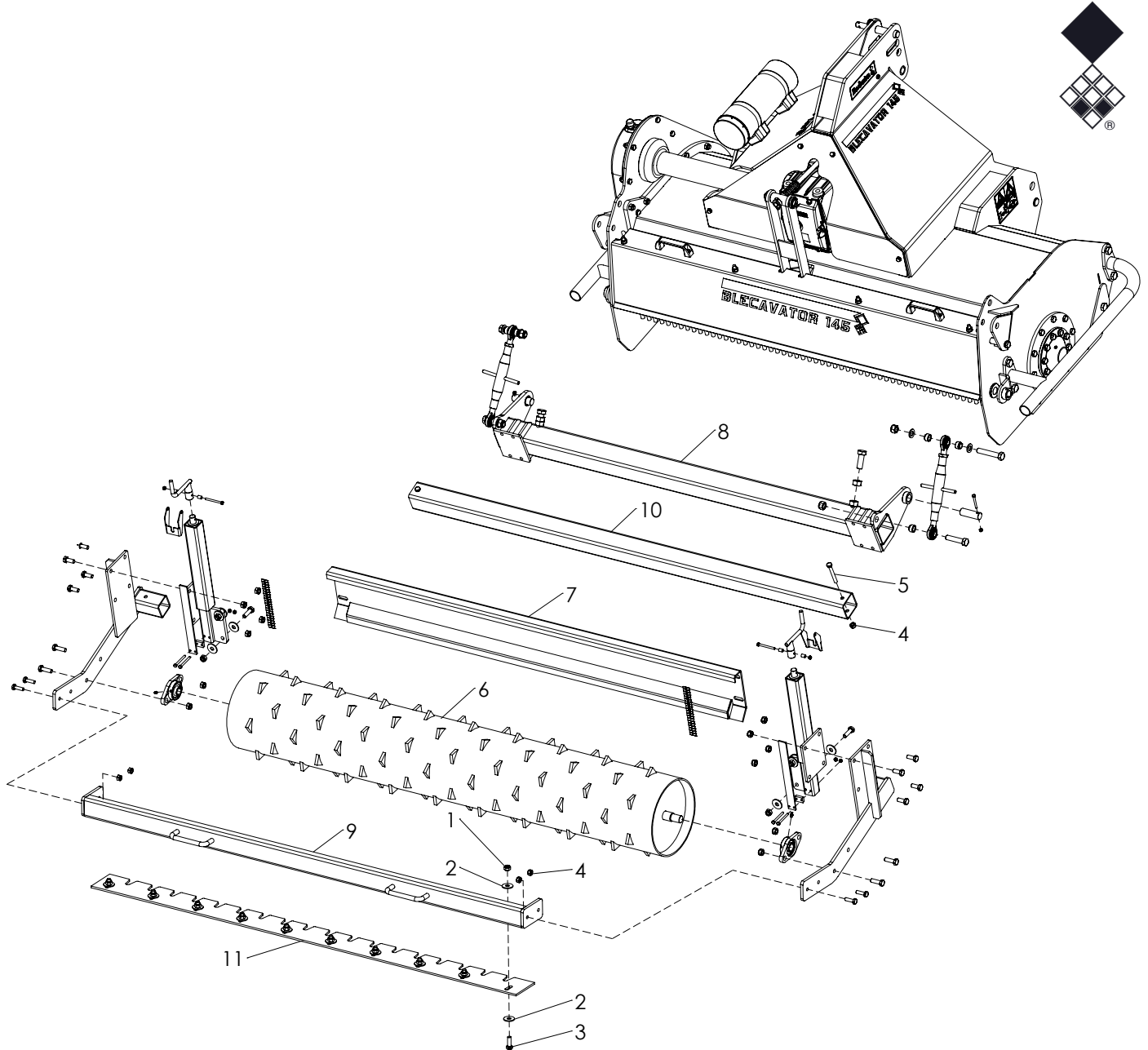

ITEM	PART NUMBER	DESCRIPTION	REMARKS	QUA 145	QUA 210
1	830.120.120	Self Lock Nut M12 - ISO 10511 Class 10		10	14
2	864.120.031	Large washer M12 - DIN 9021		20	28
3	804.120.350	Bolt M12 x 35 - ISO 4017		10	14
4	830.100.100	Self Lock Nut M10 - ISO 10511		6	6
5	802.100.850	Bolt M10 x 85 - ISO 4014		2	2
6	488.178.242	Rear roller		1	0
	488.319.242	Rear roller		0	1
7	468.196.165	Deflector plate		1	0
	468.039.229	Deflector plate		0	1
8	462.232.916	Subframe rear roller		1	0
	462.229.229	Subframe rear roller		0	1
9	470.179.070	Scraper beam		1	0
	470.242.070	Scraper beam		0	1
10	472.701.760	Square tube		1	0
	472.702.400	Square tube		0	1
11	468.069.172	Scraper		1	0
	468.069.117	Scraper		0	2

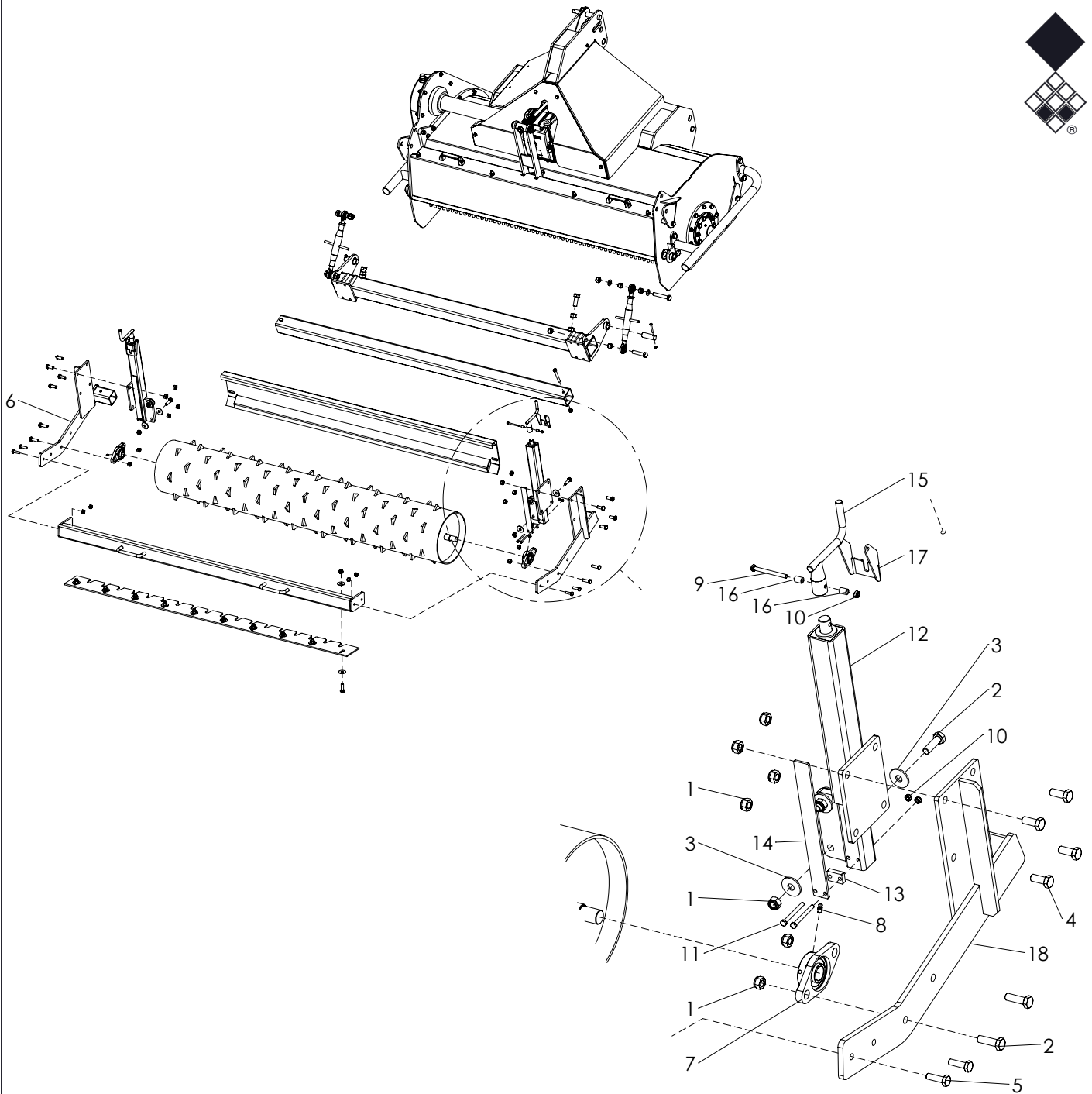

ITEM	PART NUMBER	DESCRIPTION	REMARKS	QUA
1	830.120.120	Self Lock Nut M12 - ISO 10511 Class 10		16
2	804.120.400	Bolt M12 x 40 - ISO 4017		8
3	864.120.031	Large washer M12 - DIN 9021		8
4	804.120.300	Bolt M12 x 30 - ISO 4017		8
5	804.100.350	Bolt M10 x 35 - ISO 4017		4
6	494.190.059	Frame rear roller LH		1
7	742.250.360	Bearing UCFL 205		2
8	880.060.100	Grease nipple M6 DIN 71412A		2
9	802.060.650	Bolt M6 x 65 - ISO 4014		2
10	830.060.060	Self Lock Nut M6 - ISO 10511		6
11	802.060.600	Bolt M6 x 60 - ISO 4014		4
12	460.503.450	Weldment spindle		2
13	464.080.300	Distance Block		2
14	464.042.800	Height Indicator Strip, L= 280		2
15	474.251.162	Lever Jack		2
16	402.070.140	Distance Bush		2
17	468.031.180	Lock Plate		2
18	494.190.058	Frame rear roller RH		1

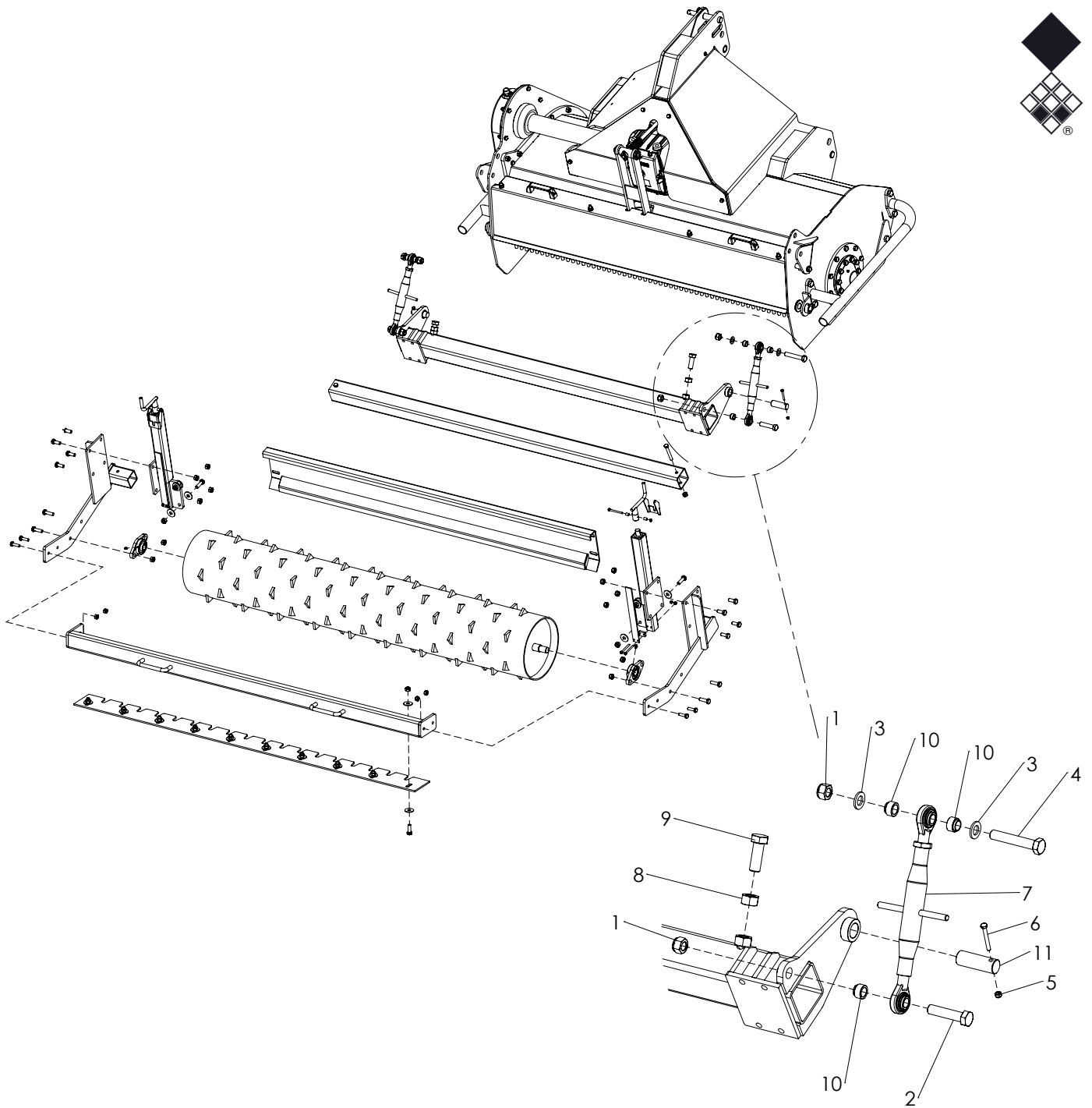

ITEM	PART NUMBER	DESCRIPTION	REMARKS	QUA
1	830.160.160	Self Lock Nut M16-ISO 10511 Class 10		14
2	802.160.700	Bolt M16 x 70 - ISO 4014 - 10.9		2
3	864.160.030	Washer M16 - ISO 7089		10
4	802.160.900	Bolt M16 x 90 - ISO 4014		2
5	830.060.060	Self Lock Nut M6 - ISO 10511		2
6	802.060.500	Bolt M6 x 50 - ISO 4014		2
7	522.163.000	Toplink Cat. 0 L0=300 Stroke=130mm		2
8	826.180.180	Nut M18 - DIN 934		2
9	804.180.500	Bolt M18 x 50 - ISO 4017		2
10	406.160.230	Distance bush		6
11	424.250.660	Pin		2

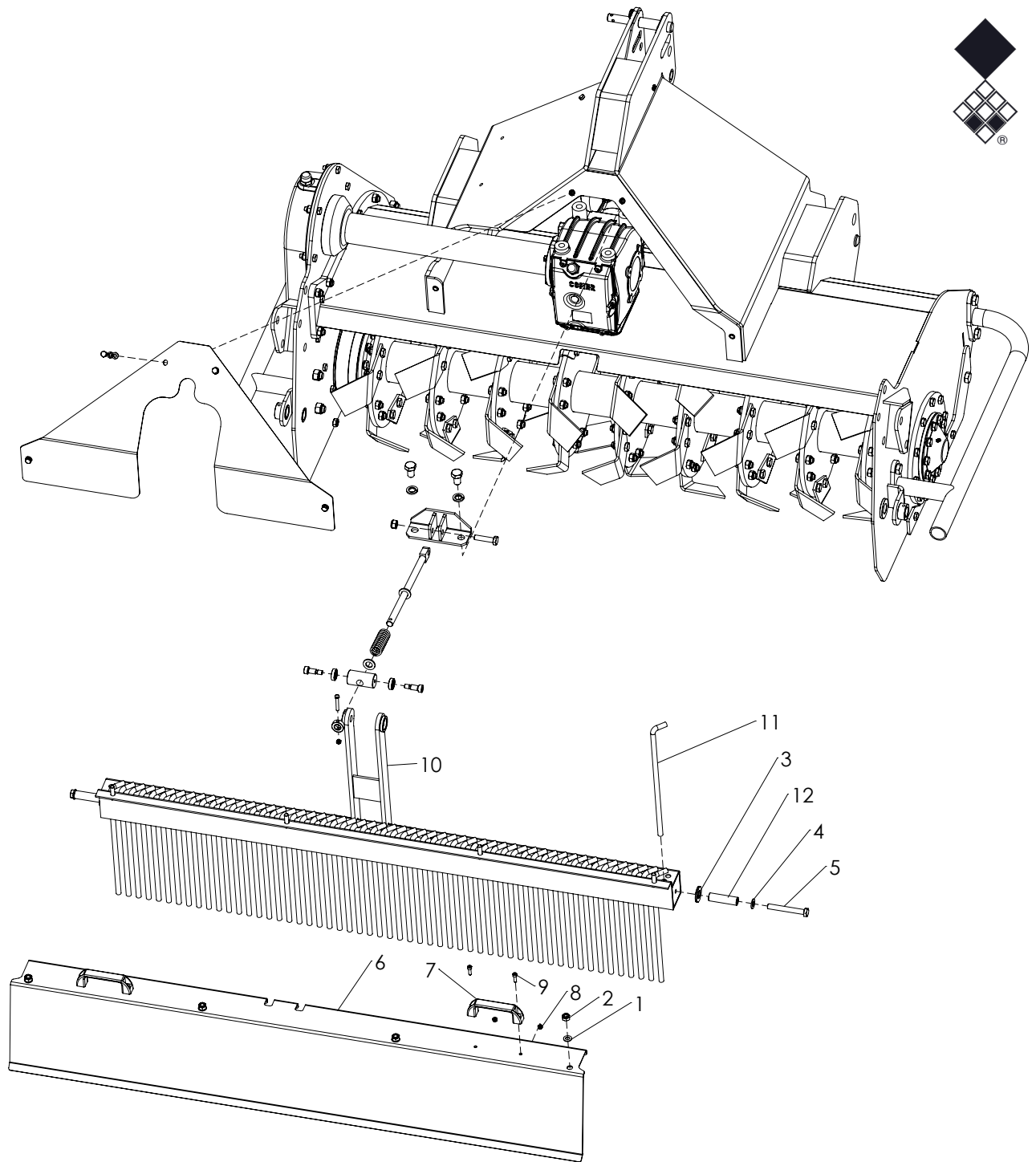

ITEM	PART NUMBER	DESCRIPTION	REMARKS	QUA 145	QUA 210
1	864.100.030	Washer M10 - ISO 7089		4	4
2	830.100.100	Self Lock Nut M10 - ISO 10511		4	4
3	864.240.044	Washer M24 - ISO 7089		2	2
4	864.120.030	Washer M12 - ISO 7089		2	2
5	802.120.950	Bolt M12 x 95 - ISO 4014		2	2
6	456.148.024	Plate		1	0
	456.212.034	Plate		0	1
7	444.151.250	Handle		2	2
8	830.060.060	Self Lock Nut M6 - ISO 10511		4	4
9	814.060.200	Bolt M6 x 20 - DIN 912		4	4
10	494.148.425	Tine bar		1	0
	494.212.425	Tine bar		0	1
11	472.123.970	Tine		56	80
12	402.120.700	Distance bush Ø20/Ø12 L=70		2	2

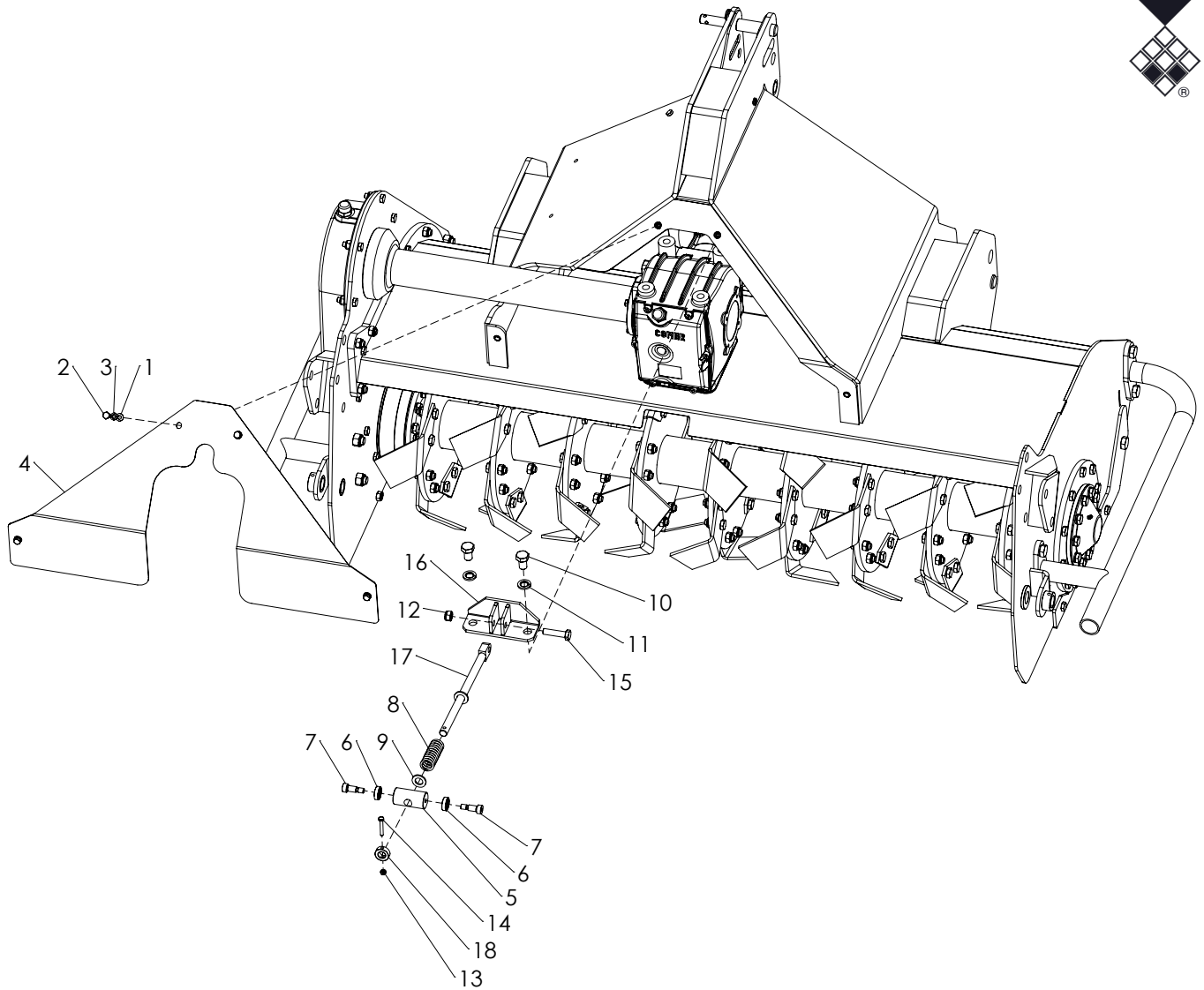

ITEM	PART NUMBER	DESCRIPTION	REMARKS	QUA
1	864.080.030	Washer M8 - ISO 7089		4
2	804.080.200	Bolt M8 x 20 - ISO 4017		4
3	866.080.020	Spring Washer M8 - DIN 127		4
4	456.758.366	Cover plate		1
5	402.350.670	Bush		1
6	4813330	Bearing		2
7	813.120.200	ISO 7379 - M10 - 12x20		2
8	576.200.900	Spring		1
9	864.160.030	Washer M16 - ISO 7089		1
10	804.160.250	Bolt M16 x 25 - ISO 4017		2
11	866.160.020	Spring Washer M16 - DIN 127		2
12	830.120.120	Self Lock Nut M12 - ISO 10511 Class 10		1
13	830.060.060	Self Lock Nut M6 - ISO 10511		1
14	802.060.400	Bolt M6 x 40 - ISO 4014		1
15	802.120.500	Bolt M12 x 50 - ISO 4014 - 10.9		1
16	468.051.202	Bracket		1
17	474.163.180	Shaft		1
18	412.160.110	Washer		1

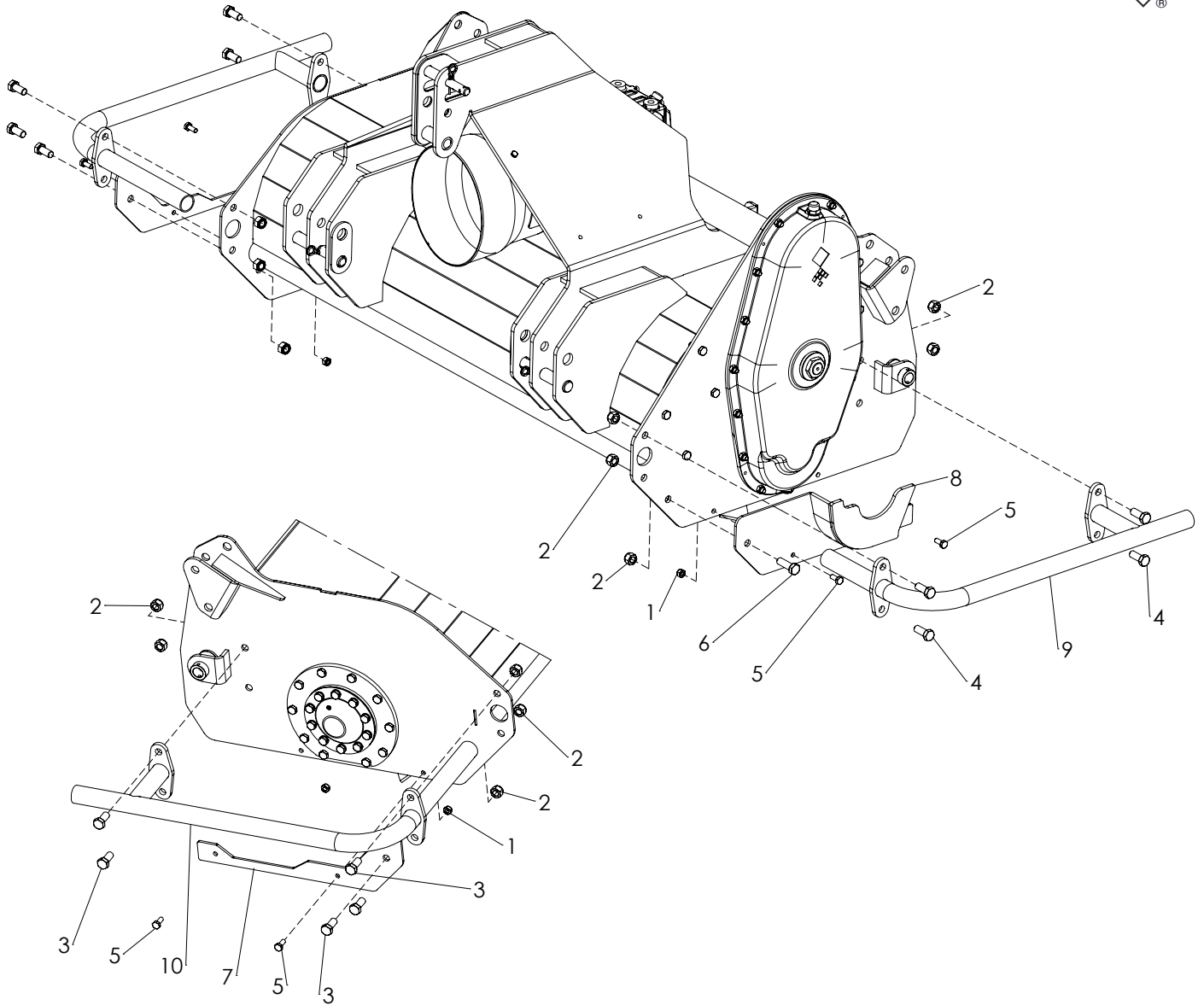

ITEM	PART NUMBER	DESCRIPTION	REMARKS	QUA 145	QUA 210
1	830.100.100	Self Lock Nut M10 - ISO 10511		4	4
2	830.160.160	Self Lock Nut M16-ISO 10511 Class 10		10	10
3	804.160.350	Bolt M16 x 35 - ISO 4017		5	5
4	804.160.402	Bolt M16 x 40 - ISO 4017 Class 10.9		4	4
5	804.100.250	Bolt M10 x 25 - ISO 4017		4	4
6	802.160.500	Bolt M16 x 50 - ISO 4014		1	1
7	468.065.352	Wear strip		1	1
8	470.535.172	Wear protection cover		1	1
9	478.150.832	Barrier		1	0
	478.150.830	Barrier		0	1
10	478.150.830	Barrier		1	1

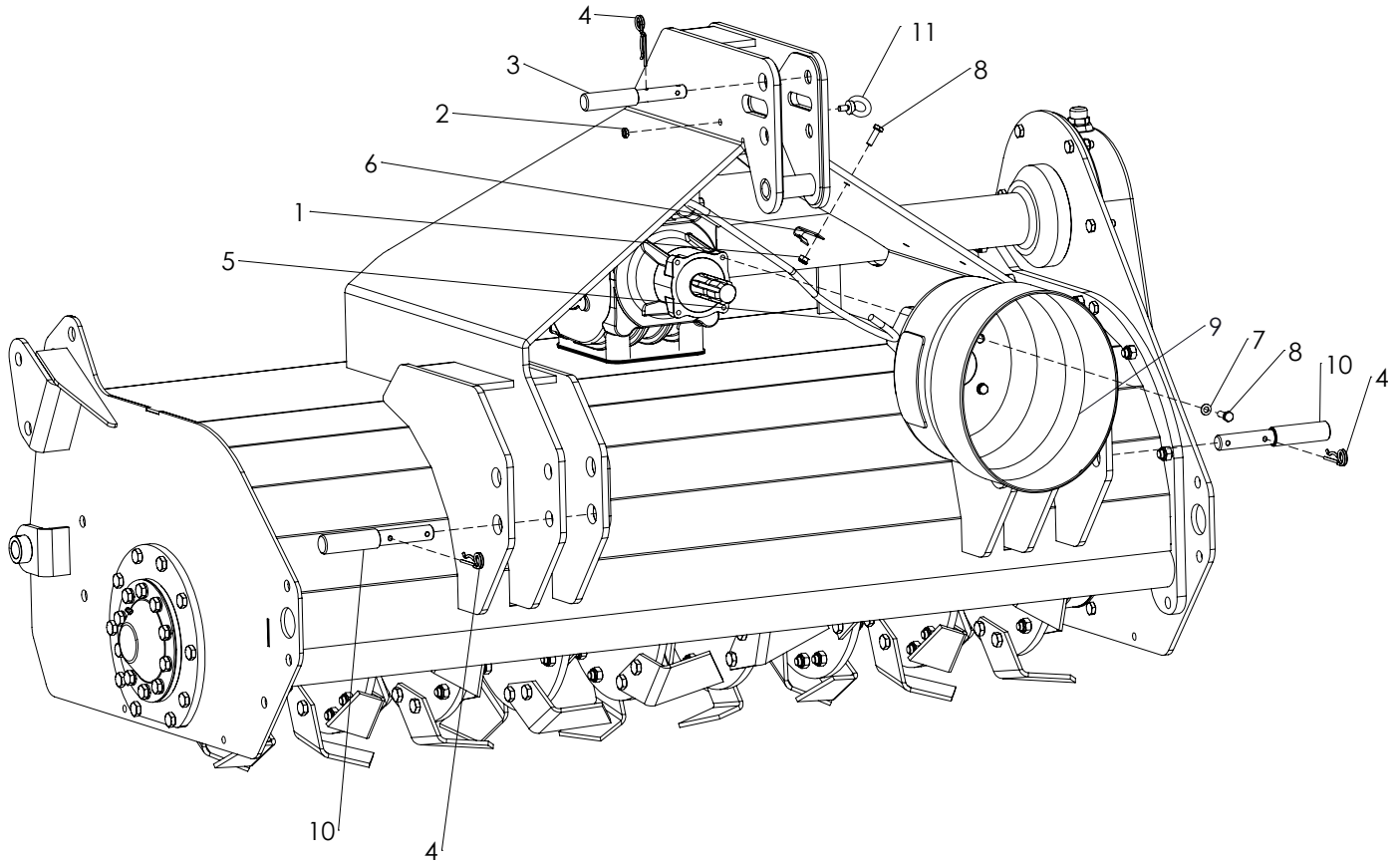

ITEM	PART NUMBER	DESCRIPTION	REMARKS	QUA
1	830.080.080	Self Lock Nut M8 - ISO 10511		1
2	826.100.500	Low Nut M10 - DIN 439		1
3	521.191.600	Top link pin OS		1
4	523.030.750	R-Clip Round 3, DIN 11024		3
5	472.107.100	Hook		1
6	464.020.820	Lock strip		1
7	864.080.030	Washer M8 - ISO 7089		4
8	804.080.250	Bolt M8 x 25 - ISO 4017		5
9	629.275.240	PTO Cover 4xØ10 PD105		1
10	521.221.600	3-point pin		2
11	822.100.362	Lifting Eye Bolt M10 - DIN 580		1

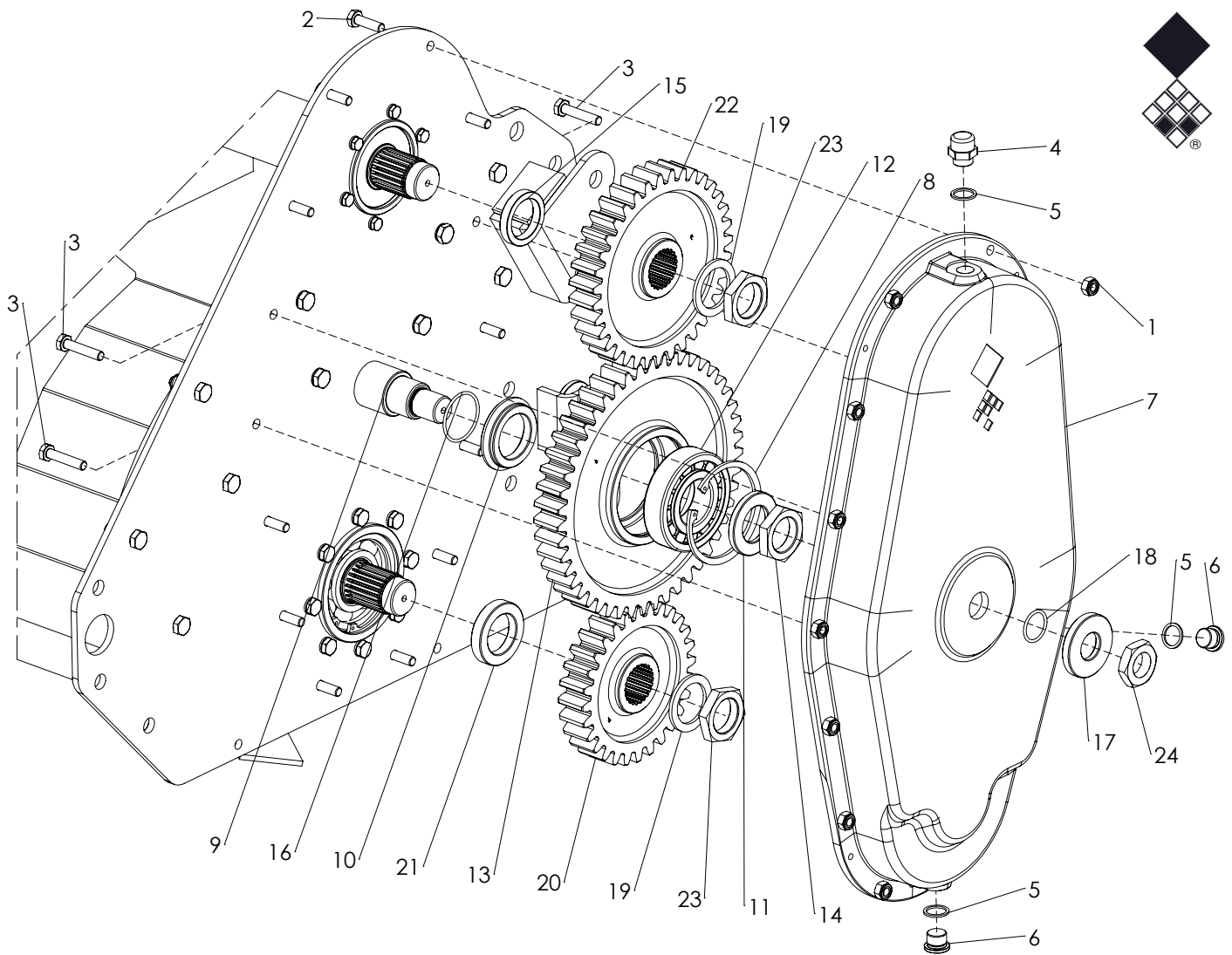

ITEM	PART NUMBER	DESCRIPTION	REMARKS	QUA
1	830.100.100	Self Lock Nut M10 - ISO 10511		14
2	804.100.350	Bolt M10 x 35 - ISO 4017		11
3	802.100.500	Bolt M10 x 50 - ISO 4014		3
4	537.120.300	Breather 1/2"		1
5	874.210.020	Copper washer 1_2		3
6	549.210.200	Blind plug G1/2		2
7	448.746.380	Gear cover		1
8	872.110.400	Circlip D=110 - DIN 472		1
9	488.065.121	Shaft		1
10	406.500.140	Distance bush		1
11	406.410.080	Distance bush		1
12	721.500.270	Cylindrical roller bearing		1
13	432.352.940	Gear 47T, Module 6, b35		1
14	472.120.602	Crank shaft nut M40x1.5		1
15	406.450.112	Distance bush		1
16	766.490.030	O-Ring Ø49x3		1
17	456.070.010	Washer		1
18	766.300.030	O-Ring Ø30x3		1
19	406.460.030	Washer		2
20	432.351.800	Gear 28T, Module 6, b35		1
21	406.450.142	Distance bush		1
22	432.352.220	Gear 35T, Module 6, b35		1
23	472.120.602	Crank shaft nut M40x1.5		2
24	844.300.120	Nut M30x2 h=12		1

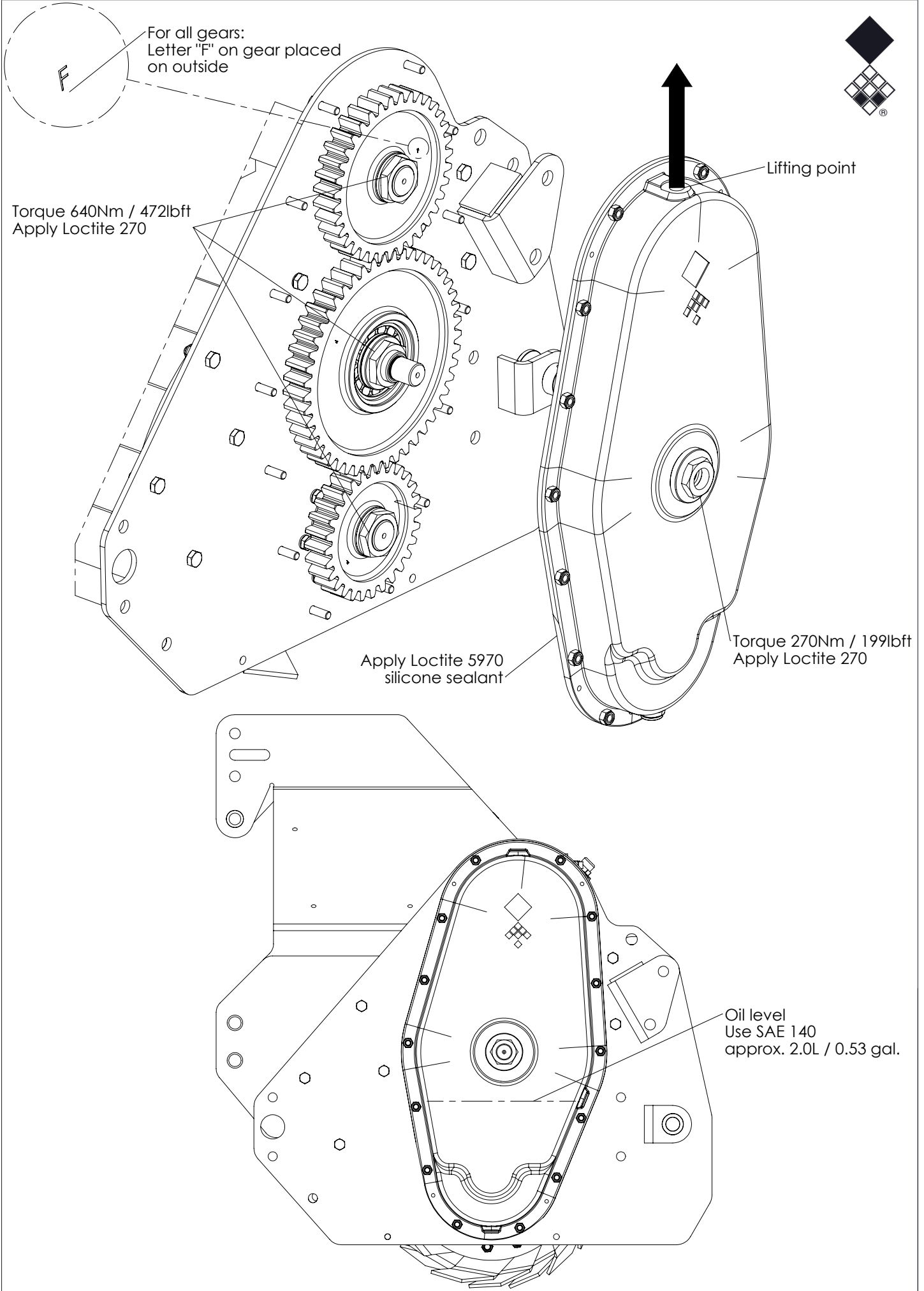

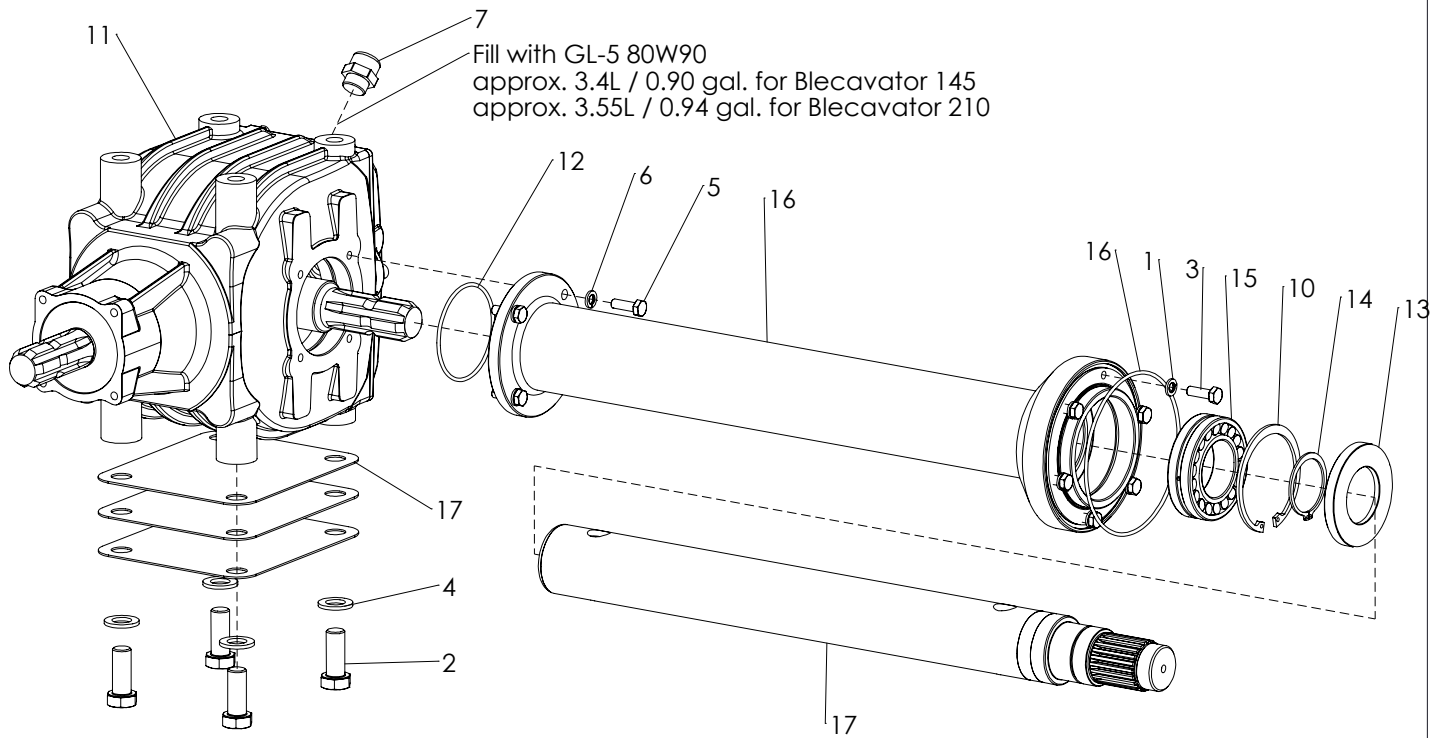

Fill with GL-5 80W90
 approx. 3.4L / 0.90 gal. for Blecavator 145
 approx. 3.55L / 0.94 gal. for Blecavator 210

ITEM	PART NUMBER	DESCRIPTION	REMARKS	QUA 145	QUA 210
1	866.080.020	Spring Washer M8 - DIN 127		6	6
2	804.160.402	Bolt M16 x 40 - ISO 4017 Class 10.9		4	4
3	804.080.250	Bolt M8 x 25 - ISO 4017		6	6
4	864.160.030	Washer M16 - ISO 7089		4	4
5	804.080.250	Bolt M8 x 25 - ISO 4017		4	4
6	866.080.020	Spring Washer M8 - DIN 127		4	4
7	537.120.300	Breather 1/2"		1	1
8	478.150.612	Drive shaft tube		1	0
	478.150.931	Drive shaft tube		0	1
9	478.061.633	Drive shaft		1	0
	478.061.952	Drive shaft		0	1
10	872.090.300	Circlip D=90 - DIN 472		1	1
11	622.202.294	Gearbox Comer T-22A 2.42:1		1	1
12	766.800.030	O-Ring Ø80x3		1	1
13	762.500.100	Oil seal 50-90-10		1	1
14	870.050.200	Circlip d=50 - DIN 471		1	1
15	721.500.230	Spherical roller bearing		1	1
16	766.138.030	O-Ring Ø138x3		1	1
17	468.021.908	Shim plate	Used for leveling the gearbox with side drive. Quantity may differ, check your machine	3	3

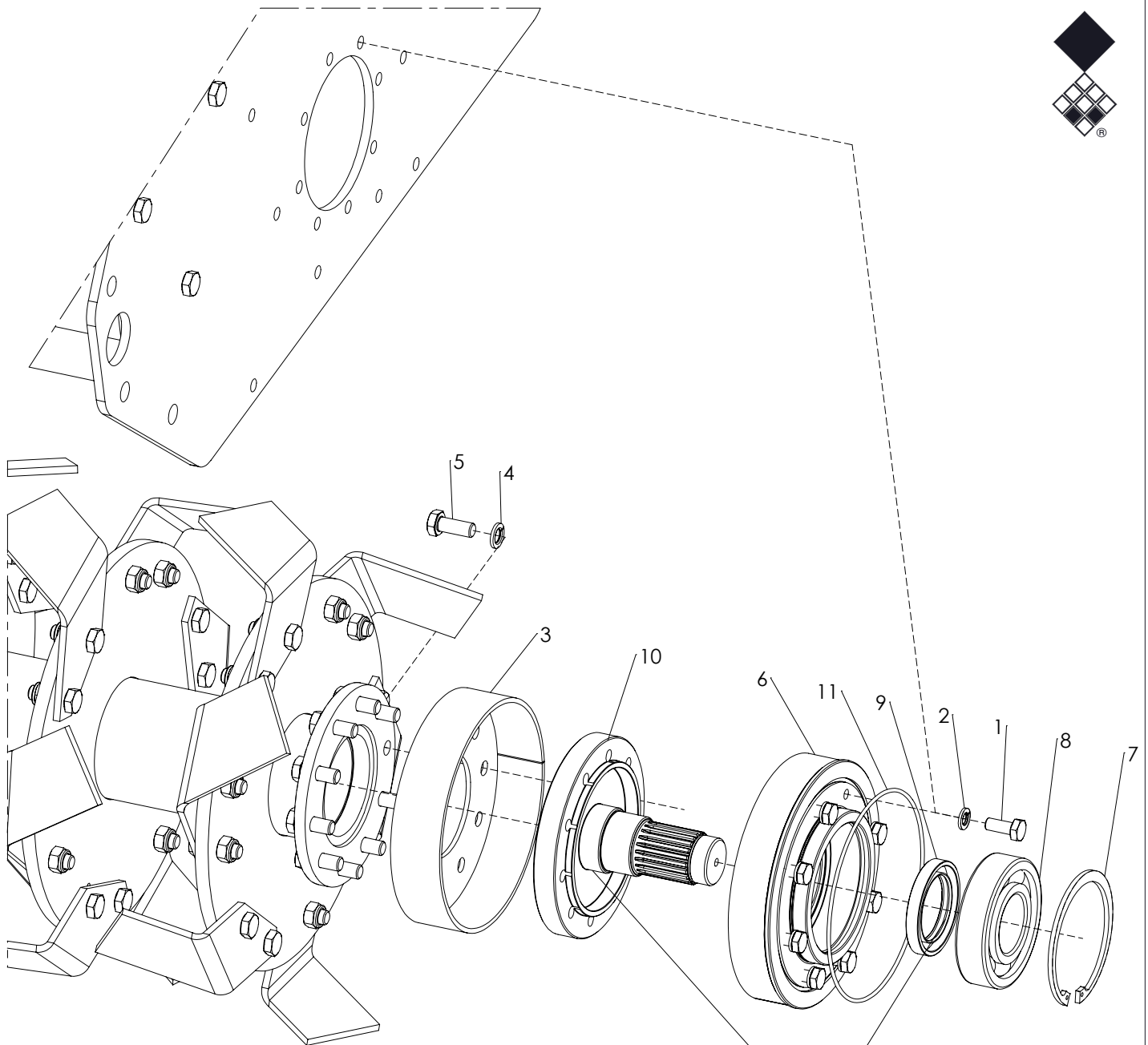

Use grease (NLGI 2) to mount the seal.

ITEM	PART NUMBER	DESCRIPTION	REMARKS	QUA
1	804.100.250	Bolt M10 x 25 - ISO 4017		8
2	866.100.020	Spring Washer M10 - DIN 127		8
3	470.198.045	Dust cover		1
4	866.120.020	Spring Washer M12 - DIN 127		10
5	804.120.302	Bolt M12 x 30 - ISO 4017 Class 10.9		10
6	470.209.053	Flange weld assy		1
7	872.110.400	Circlip D=110 - DIN 472		1
8	711.500.270	Bearing 6310		1
9	762.550.100	Oil seal 55x80x10mm type CC		1
10	488.170.144	Shaft end		1
11	766.142.030	O-Ring Ø142x3		1

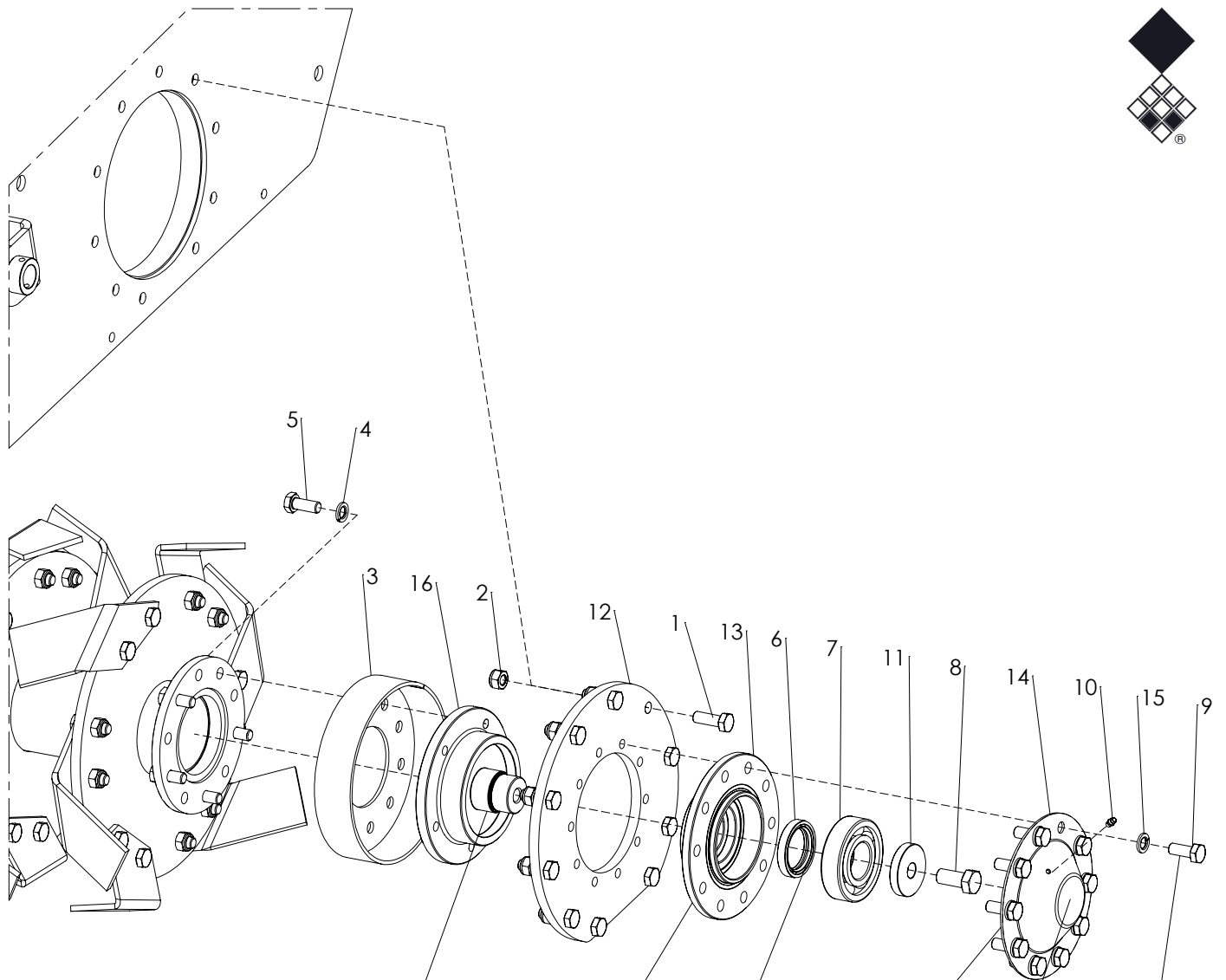

Use grease (NLGI 2) to mount the seal.

Apply loctite 5970 silicone sealant

Use grease (NLGI 2) to mount the seal.

Apply loctite 5970 silicone sealant

Apply approx. 40ml / 1.35 floz. NLGI3 grade grease

Use threadlocking sealant Loctite 243

ITEM	PART NUMBER	DESCRIPTION	REMARKS	QUA
1	804.120.350	Bolt M12 x 35 - ISO 4017		10
2	830.120.120	Self Lock Nut M12 - ISO 10511 Class 10		10
3	470.198.045	Dust cover		1
4	866.120.020	Spring Washer M12 - DIN 127		5
5	804.120.302	Bolt M12 x 30 - ISO 4017 Class 10.9		5
6	762.450.102	Oil seal 45x62x10mm type CC		1
7	4816980	Bearing 6308		1
8	804.160.350	Bolt M16 x 35 - ISO 4017		1
9	804.120.300	Bolt M12 x 30 - ISO 4017		10
10	880.060.100	Grease nipple M6 DIN 71412A		1
11	410.160.100	Washer		1
12	468.122.802	Flange support		1
13	478.180.044	Flange		1
14	456.180.033	Side cover		1
15	866.120.020	Spring Washer M12 - DIN 127		10
16	488.170.093	Shaft end		1



Place blades on the rotor in a spiral shape

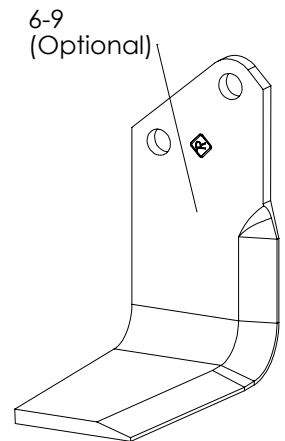
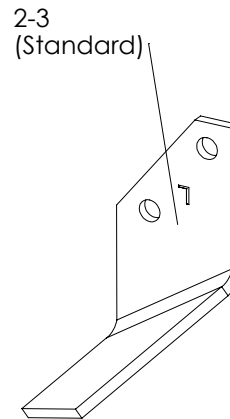
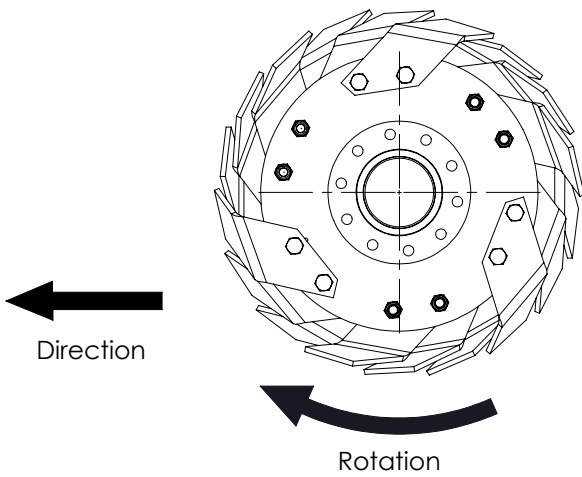
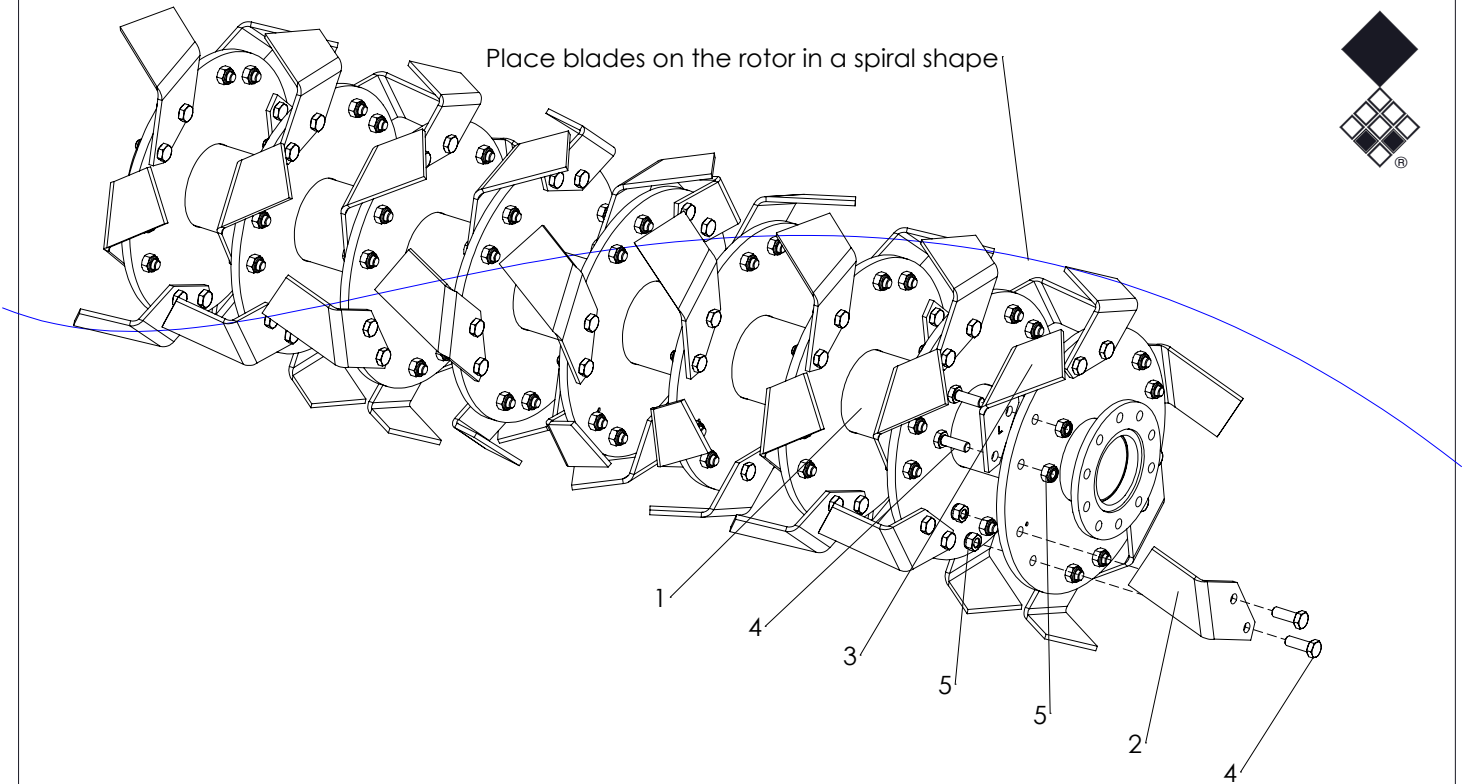

ITEM	PART NUMBER	DESCRIPTION	REMARKS	QUA 145	QUA 210
1	494.139.033	Weldment rotor		1	0
	494.204.033	Weldment rotor		0	1
2	2986040	Stone burrier blade RH	Standard, Marked with "R"	27	39
3	2986042	Stone burrier blade LH	Standard, Marked with "L"	27	39
4	804.120.350	Bolt M12 x 35 - ISO 4017		108	156
5	830.120.120	Self Lock Nut M12 - ISO 10511 Class 10		108	156
6	351.308.180	Blade Blecavator 8mm Left	Optional	24	36
7	351.308.181	Blade Blecavator 8mm Right short	Optional	3	3
8	351.308.182	Blade Blecavator 8mm Right	Optional	24	36
9	351.308.183	Blade Blecavator 8mm Left short	Optional	3	3

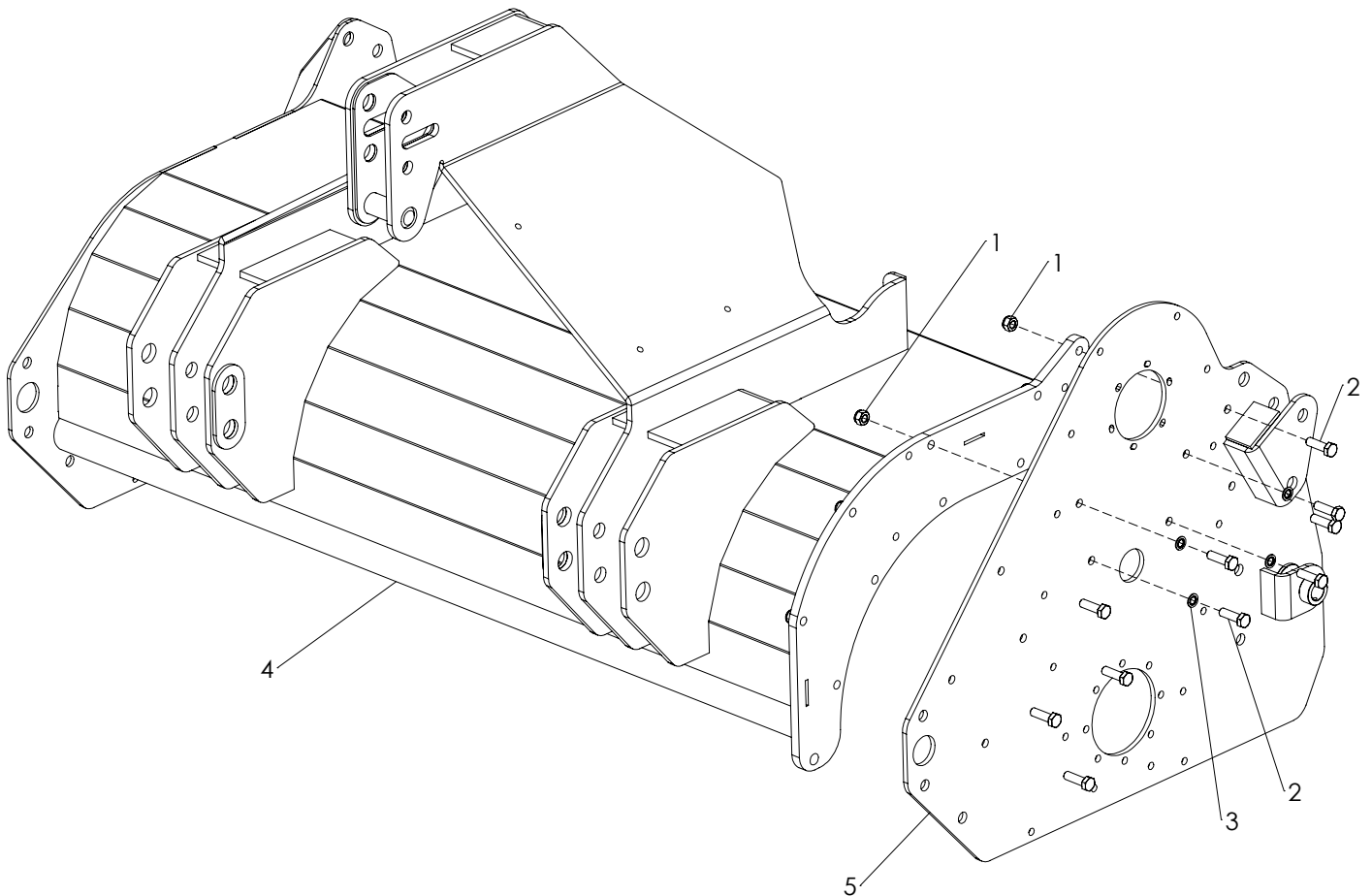

ITEM	PART NUMBER	DESCRIPTION	REMARKS	QUA 145	QUA 210
1	830.120.120	Self Lock Nut M12 - ISO 10511 Class 10		10	10
2	804.120.402	Bolt M12 x 40 - ISO 4017 Class 10.9		10	10
3	769.120.020	Bonded seal ring M12		4	4
4	494.156.093	Frame Blecavator 145		1	0
	494.217.076	Frame Blecavator 210		0	1
5	494.076.065	Weld assy side plate left		1	1

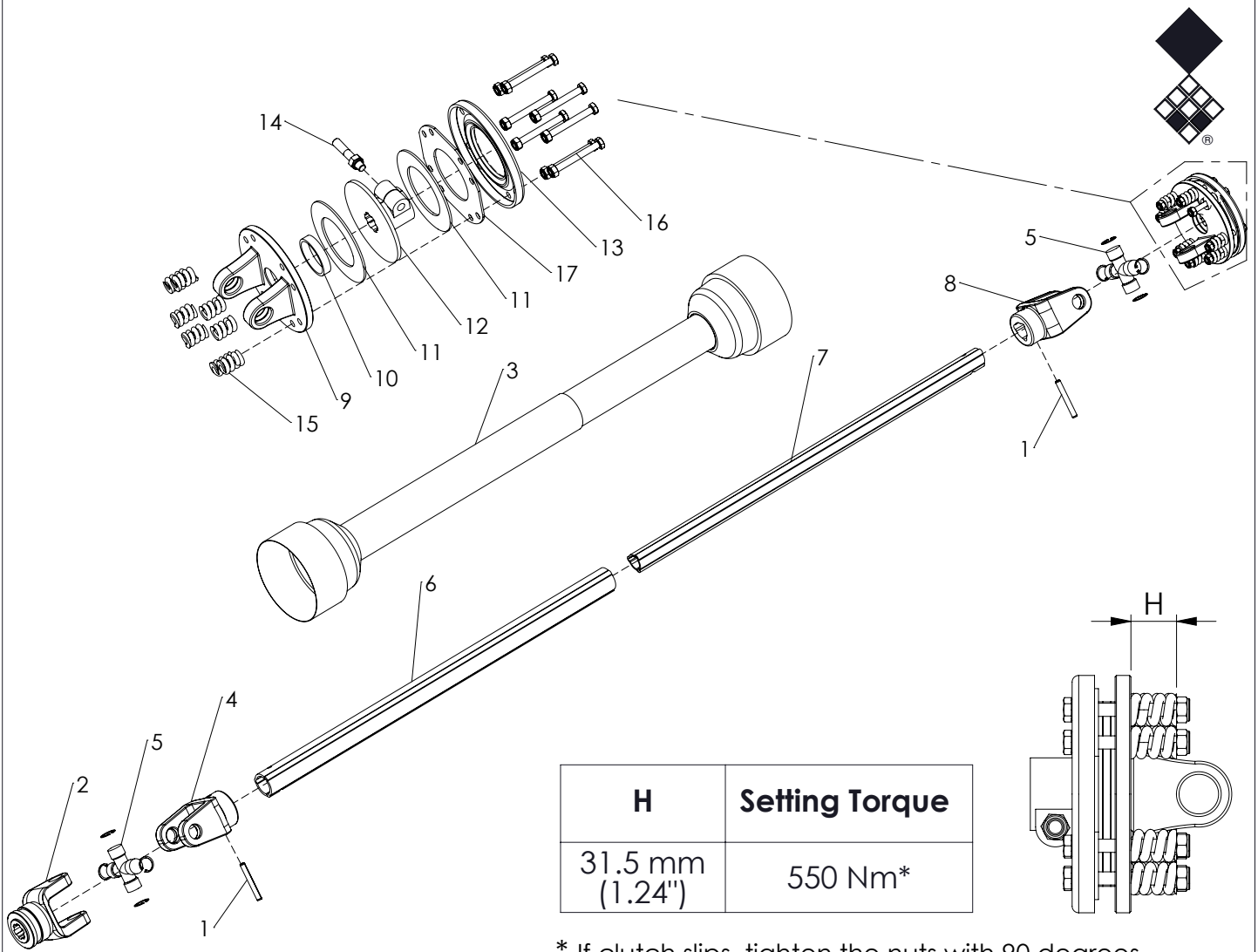

H	Setting Torque
31.5 mm (1.24")	550 Nm*

* If clutch slips, tighten the nuts with 90 degrees at a time to a maximum of 30.5mm (1.20") = +200Nm

ALWAYS deburr parts when cut
MEASURE correct length of PTO first
MAINTAIN slipclutch every month
NEVER USE PTO over 30 degrees
SLIPCLUTCH always on machine side

ITEM	PART NUMBER	DESCRIPTION	REMARKS	QUA
1	19000018	Outer roll pin		2
2	BEN PT140119	End yoke with quick lock		1
3	BEN PT143249	Safety guard group	Cut to correct length	1
4	BEN PT143666	Outer tube yoke		1
5	BEN PT151242	Universal joint assembled		2
6	BEN PT154926	Tubing cut to size	Cut to correct length	1
7	BEN PT157727	Tubing cut to size	Cut to correct length	1
8	BEN PT158836	Inner tube yoke		1
9	BEN F1B06	Flange yoke		1
10	BEN F060	Bush		1
11	BEN F030/S	Lining ring		2
12	BEN F138	Hub		1
13	BEN F1180	Pressure plate		1
14	BEN 90938	Conic bolt and nut		1
15	BEN F0111	Spring		8
16	BEN F10085	Bolt and nut		8
17	BEN F070	Inner plate		1
	611.601.200	PTO shaft type T-60 tl 1200		
	611.606.100	PTO shaft type T-60 tl 610		