

Ariens



Operating Instructions

Safety

1. Read the instructions carefully. Be familiar with controls and the use of equipment.
2. Do not operate the engine in a confined space where dangerous fumes can collect.
3. Mow only in daylight or in very good artificial light.
4. Before starting the engine, disengage blade and attachment drives and make sure handbrake is engaged.
5. Take care on slopes – maximum 15°.
6. Remember, there is no such thing as a 'safe slope'. Travel on grass slopes requires particular care to guard against overturning:
 - Do not stop or start suddenly when going up or downhill.
 - Engage drive slowly. Always keep the machine in drive when travelling up or down a slope.
 - Machine speed should be kept low on slopes and in tight turns.
 - Stay alert for humps and hollows and other hidden hazards.
 - Avoid mowing across the face of a slope.
7. Watch out for traffic when crossing or working near roadways.
8. Stop the blades rotating before crossing roadways.
9. When using the machine, never direct discharge or material towards bystanders or allow anyone near the machine while in operation.
10. Never operate the mower with defective guards, shields or without protective safety devices in place and in good working order.
11. Do not change governor settings to increase the speed of the engine. Operating an engine at excessive speed increases the risk of injury.
12. Before leaving the operator's position:
 - Disengage the drive to the cutter blades and attachments, then lower the attachments.

- Apply the Parking Brake.
 - Stop the engine and remove the ignition key.
13. Always disengage drive to attachments, stop the engine and remove the ignition key before:
 - Cleaning blockages.
 - Checking, cleaning or working on the mower.
 - Refuelling.
 - Removing the Grass Collector.

Also:

- After striking a foreign object inspect the mower for damage and make any repairs before restarting the tractor.
 - If the machine starts to vibrate abnormally, check immediately and call your dealer if necessary.
14. Disengage drive to attachments when transporting or not in use.
 15. Reduce the throttle setting during engine run-out.
 16. Never work on the mower when the engine is running.

Always:

Use good common sense at all times and to ensure this tractor is safe and serviceable fit only original manufacturer's supplied spares.

- Inspect the area to be cut, note the position of any stumps, drain covers, bumps or depressions and avoid them to prevent damaging the blades.
- Ensure the fuel tank is full before you start the machine.
- ONLY use the specified fuel for your machine.
- Disconnect both battery terminals before attempting any work in the engine compartment.

Never:

- Leave the tractor unattended and running.
- Put hands near moving blades, belts or the Power Take-Off pulley while they are rotating.

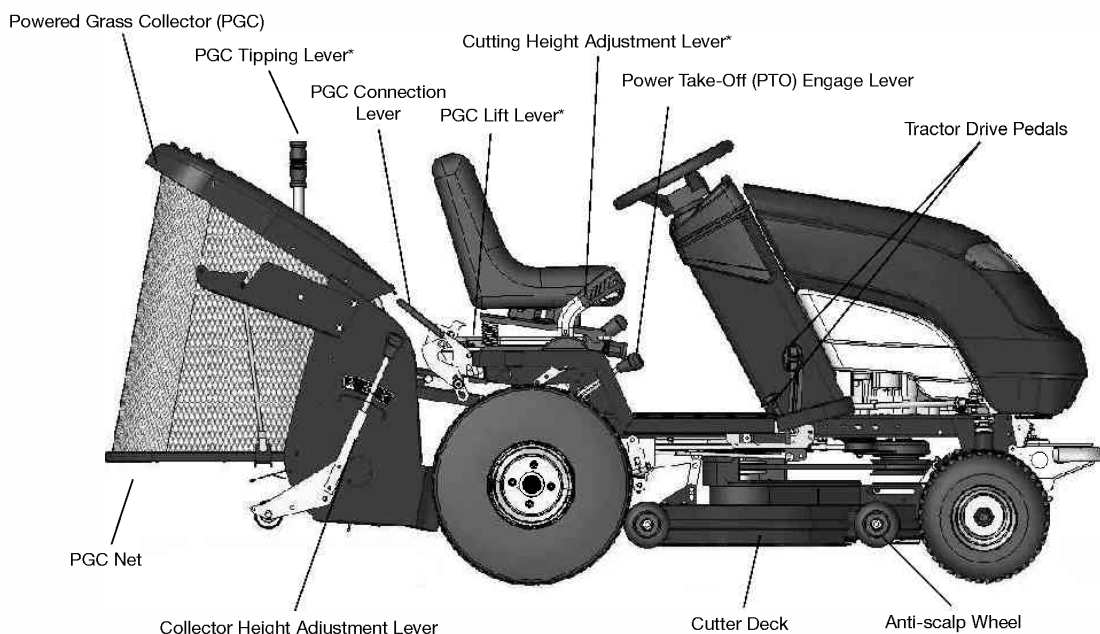

Operating Instructions, Controls

Seat Adjustment (Fig. 1)

The seat on your tractor is adjustable forward and backward to suit the operator. Simply lift the seat latch at the side of the seat and slide the seat forward or backward as appropriate. Always ensure the seat is latched back into position before driving off.

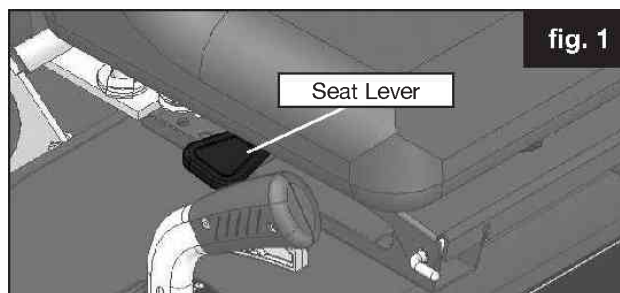

Choke (Fig. 2)

An independent choke is fitted to some models. This choke should be used in conjunction with a fast throttle setting when starting the engine from cold. It should be cancelled as soon as possible. Do not use the choke when starting a warm engine.

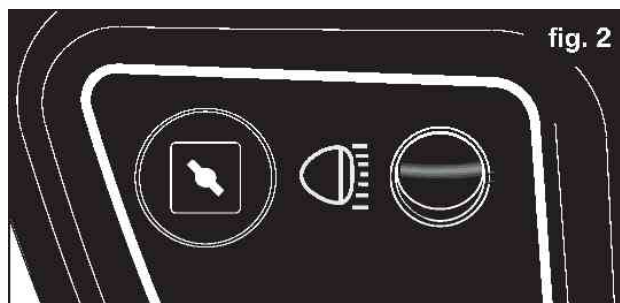

Ignition (Figs. 3, 6 & 11)

The key start controls the ignition and the start button engages the starter. The engine cannot be started without the park brake being on; the "P" light (Fig. 11) indicates the brake is engaged (not applicable to the Mini). When starting your tractor from cold, turn the key to the I position. Once the cycle has finished press the start button to start the Tractor. Release the button when the engine starts. To stop the engine, turn the key to the left (having first switched off both the cutter and Power Take-off). To prevent unauthorised use, always remove the key after use. THE IGNITION MUST ALWAYS BE TURNED OFF AND LEFT FOR AT LEAST TWO SECONDS BEFORE THE TRACTOR CAN BE RE-STARTED.

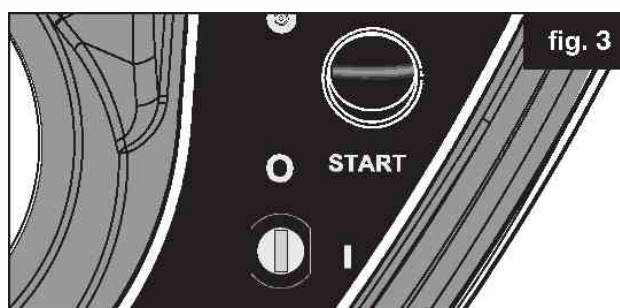

Operating Instructions, Controls

Engine Speed Control (Fig. 4)

The lever is pushed up for FAST (👉) and down for SLOW (👈). On some models the choke control is above the fast setting, a cold engine is started on the Choke setting, a warm one on the FAST setting. The Choke setting should be cancelled as soon as possible. The engine should be operated on the FAST setting at all times.

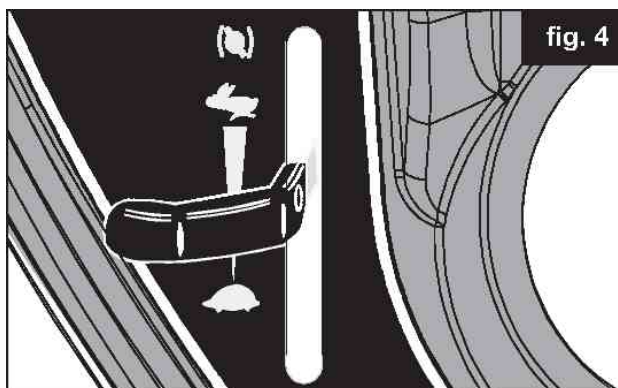

fig. 4

RPM Meter

(not applicable to Mini tractor) (Fig. 5)

The RPM monitor on the electronic display indicates the engine speed. This feature should be used when the cutter deck is engaged and in conjunction with the forward speed. To ensure complete cutting and collection the engine speed should not be allowed to fall below 2600rpm, the display will flash should this happen. If, when in use, the display does flash indicating that the engine speed has dropped below 2600rpm, there are two options: a) Reduce forward speed b) Raise the cutting height.

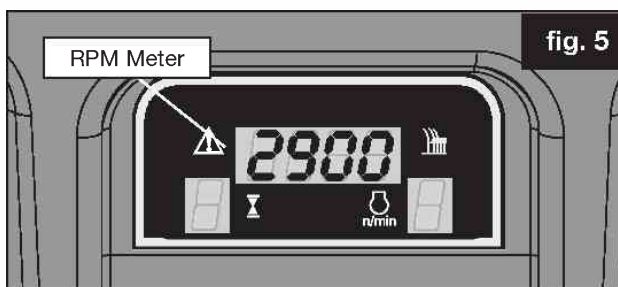

fig. 5

Operating Instructions, Controls

Drive Controls (Fig. 7)

The forward speed of the tractor is controlled by foot pedal 'A'. Reversing is controlled by foot pedal 'B'.

Moving Off / Reversing (Figs. 7 & 7a)

To move off, ensure your feet are off pedals 'A' and 'B' and then release the parking brake by pushing the hand lever 'C' (Fig. 7a) to the forward position. Now gently depress pedal 'A' and you will move off. The further you depress pedal 'A' the faster you will go. Its function is similar to that of a car accelerator except that it controls the hydrostatic transmission and does not affect the speed of the engine. To reverse simply depress pedal 'B' and the tractor will begin to reverse. As with the forward pedal, the speed of reversing is increased as the pedal is pushed further.

Stopping

To stop the tractor simply release either pedal 'A' or 'B' and the natural braking of the hydrostatic system will bring the tractor to a standstill. For smooth braking release either pedal gradually, for an emergency stop remove foot rapidly.

Parking (Figs. 7 & 7a)

Remove your foot from pedals 'A' or 'B' (as you would to stop normally) and then simply pull the parking brake lever 'C' to the upright position - a 'P' will be indicated on the dashboard display (Page 6 Fig. 11). When you turn off the engine, the natural braking of the hydrostatic system will add to the effect of the brake. It's like leaving your car in gear.

Neutral Valve (Fig. 8)

The natural braking of hydrostatic transmission means that it is not possible to easily push or freewheel the tractor. To disengage, first make certain that the machine is on a flat even surface. Release the parking brake by moving lever 'C' forward. Locate the Neutral Valve, situated on the back plate near the towing bracket. Engage by pulling out the lever. You will now be able to push the tractor at a speed not exceeding 2 mph. Make sure you disengage the Neutral Valve by pushing the lever back BEFORE starting your tractor.

Differential Lock (where fitted) (Fig. 9)

Your tractor may be fitted with a differential lock. This should only be used in situations where one wheel is slipping and the other is not. In a situation when one wheel starts to slip and extra traction is required release the forward pedal so the wheels stop going around, depress the Differential Lock pedal (Fig. 9 pedal D), and then the forward pedal slowly. The differential will lock both wheels to drive at the same speed. As soon as the differential lock is not required release the engage pedal 'D' and as soon as the wheels are rotating at the same speed and not under load (i.e. on a slope) the lock will automatically release.

IMPORTANT – DO NOT ATTEMPT TO STEER THE TRACTOR WHEN THE DIFFERENTIAL LOCK IS ENGAGED. ALWAYS ENSURE THE DIFFERENTIAL LOCK IS RELEASED BEFORE MANOEUVRING IN A CLOSED AREA.

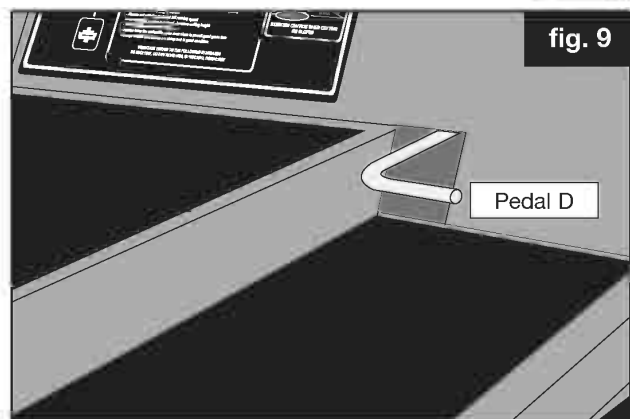
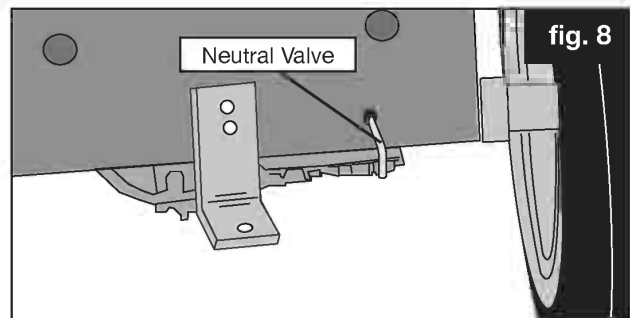
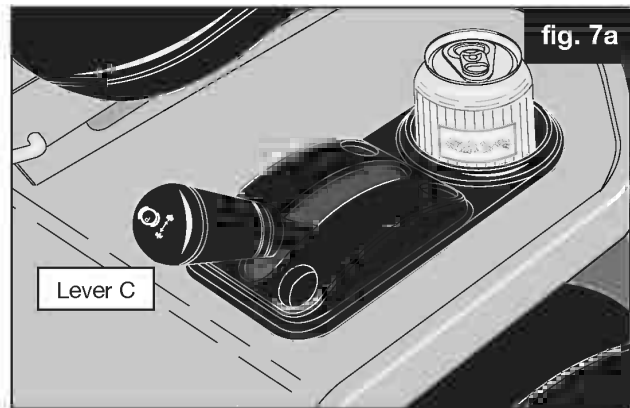
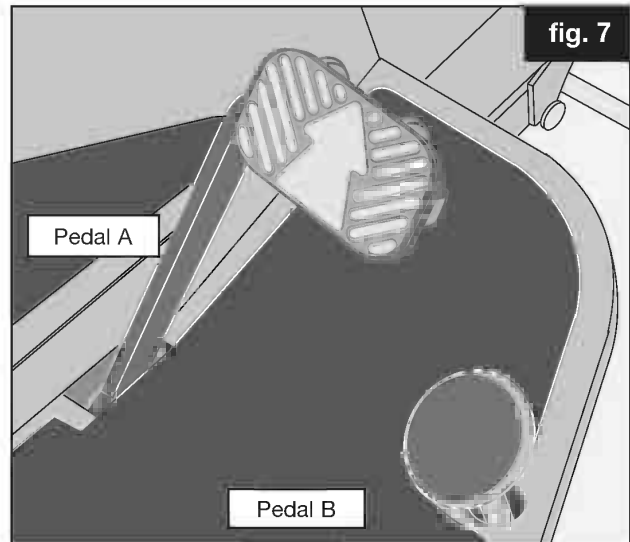

Operating Instructions, Controls

Cutter On/Off Switch (Figs. 10 & 11)

The cutter switch controls the electromagnetic blade clutch. To switch the cutter on, push the switch and then release it, this will engage the cutter deck. To indicate that the Cutter Deck is engaged, the Cutter Deck Height Indicator will flash (Fig. 11). To stop the Cutter Deck, push the switch again. Although the Cutter Deck is automatically switched off when the engine is stopped or when the operator gets off the seat, it is not good practice to rely on these features, the Cutter Deck should always be switched OFF as soon as you have finished cutting and certainly BEFORE stopping the engine or getting off the tractor. The Cutter will only work whilst the operator is sat on the seat.

NOTE: The headlights will flash whilst the Cutter Deck is running if they are not being used. If the headlights are in use they will not flash but function as normal.

Electric Lifts (not applicable to Mini tractor) (Figs. 10 & 11)

Electric deck height adjustment (where fitted)

The cutting height is adjusted by turning the rotary switch anti-clockwise to lower the deck and clockwise to raise the deck (Fig. 10). The height indicator on the electronic display (Fig. 11) shows the deck position (0 – lowest to 9 – highest). To get the best from this refinement use it to continuously adjust cutting height to suit ground and grass conditions. Do not make downward adjustments on the move until you are familiar with the height control, this will avoid “scalping” the lawn.

Manual Deck Lift (where fitted) (Fig. 12)

Your tractor may be fitted with a manual deck lift. To operate, simply push the trigger in until the weight of the deck can be felt and pull back to the desired cutting height (numbered 1-9). To lower, hold the trigger in and push forward. Exercise caution when operating lift lever.

Hour Meter (not applicable to Mini tractor) (Fig. 13)

Your tractor is fitted with an hour meter to assist you in adhering to the recommended service intervals. The hour meter only operates whilst the engine is actually running. Clocked hours will show up on the RPM display prior to starting the engine. Recommended service intervals are shown on page 25.

NOTE: 50 hours of mowing at 5 mph equates to 250 miles of grass cutting!

Low Fuel Warning

(not applicable to Mini tractor) (Fig. 14)

When the tractor is low on fuel a warning will appear where the RPM display is saying ‘FUEL’, this is a warning to tell you to fill up again as the tractor is about to run out of petrol or diesel.

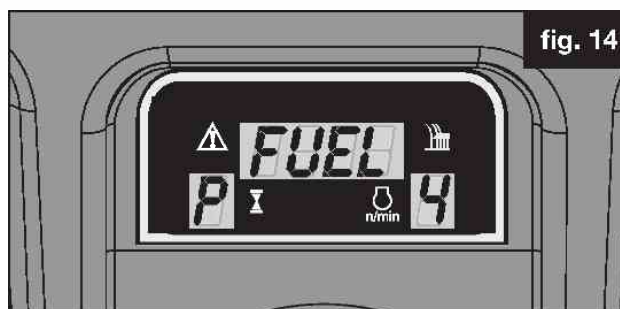
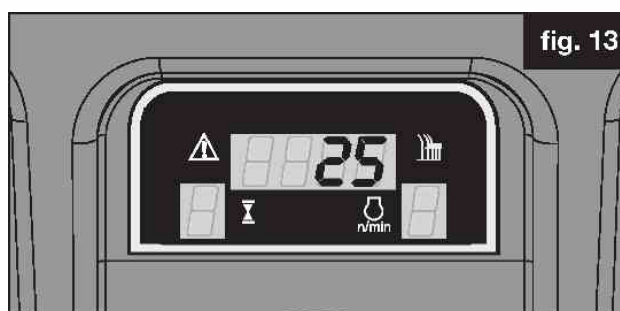
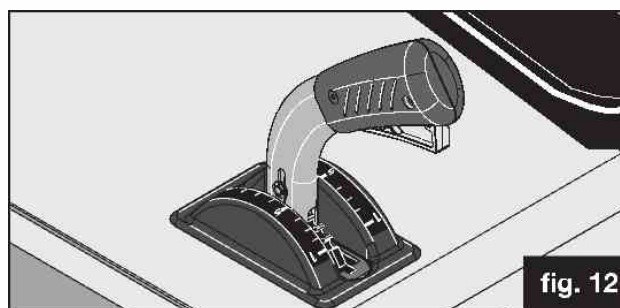
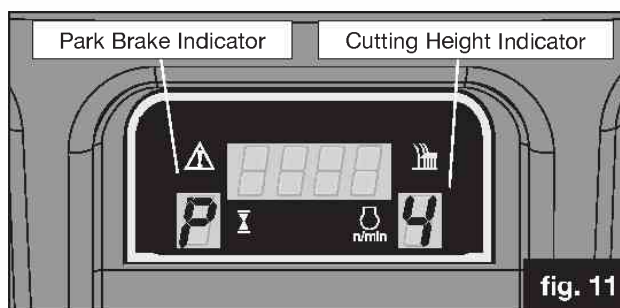
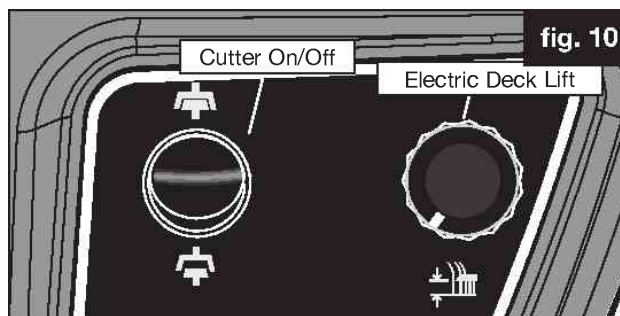

Operating Instructions, Controls

Auxiliary Lift Switch (where fitted) (Fig. 15)

Raising the Auxiliary (Grass Collector) Lift is achieved by pressing a switch (Fig. 15) on the dashboard – UP to raise, DOWN to lower.

Net Empty Switch (where fitted) (Fig. 16)

Emptying the Powered Grass Collector is achieved by pressing a switch (Fig. 16) on the dashboard – UP to open, DOWN to close.

Power Take-Off (Mini and C Series) (Fig. 17)

To engage the PTO drive, the PTO lever is lifted up and out of its locator and then moved to the left and released to find its own height. To disengage the PTO pull the lever up and to the right. Always have this lever in the 'disengaged' position when it is not in use. DO NOT PUT HANDS NEAR MOVING PULLEYS AND BELTS.

Power Take-Off (A Series) (Fig. 17a)

To engage the PTO, push the lever down and to the left and release lever upwards. The PTO lever is pushed down and to the right into its locator to disengage. Always have this lever in the 'disengaged' position when it is not in use.

DO NOT PUT HANDS NEAR MOVING PULLEYS AND BELTS.

Lights (Fig. 18)

Pressing the rocker switch turns ON the headlights. Turn the headlights OFF by pressing the rocker switch again. The headlights will not operate without the ignition switch turned on.

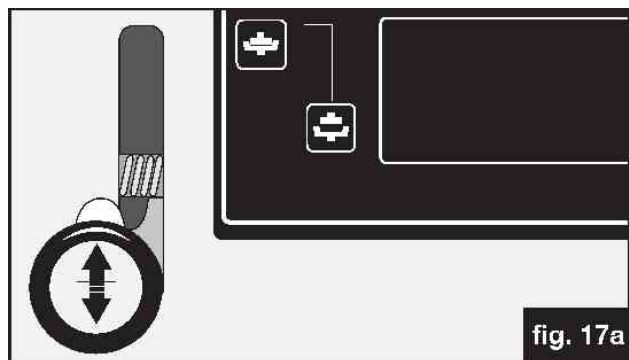
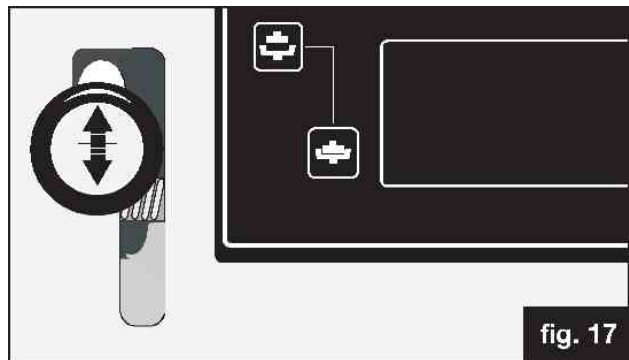
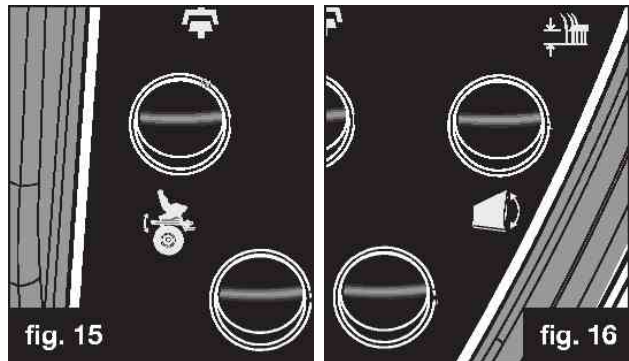

Light Switch

• •

Operating Instructions, Controls

Electronic Slope Alert (ESA)

(not applicable to Mini tractor) (Figure 18a)

Should your tractor be fitted with 4WD it will have ESA. This is set to an angle of 25° at the factory. If this angle is exceeded then the display will flash 25° and a warning siren will sound.

The exceptional traction of 4WD will allow you to cut in very slippery conditions, and it also allows the tractor to ascend very steep slopes. If the slope alarm sounds DO NOT attempt to cut or drive at a greater angle than the one you are on. As all terrains and conditions vary, great care should be maintained when operating the tractor. DO NOT take the tractor into an area where it could become unstable.

On no account should slopes steeper than 25° be driven on.



fig. 18a

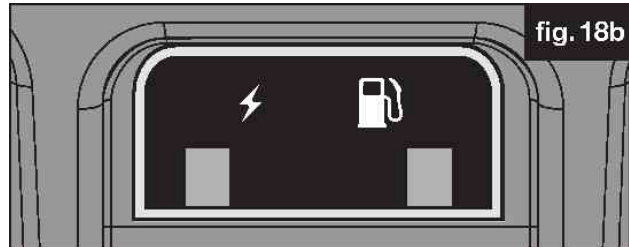
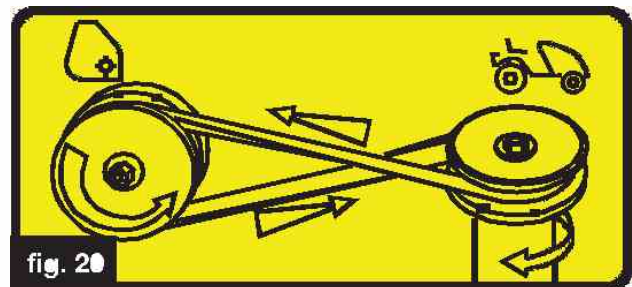
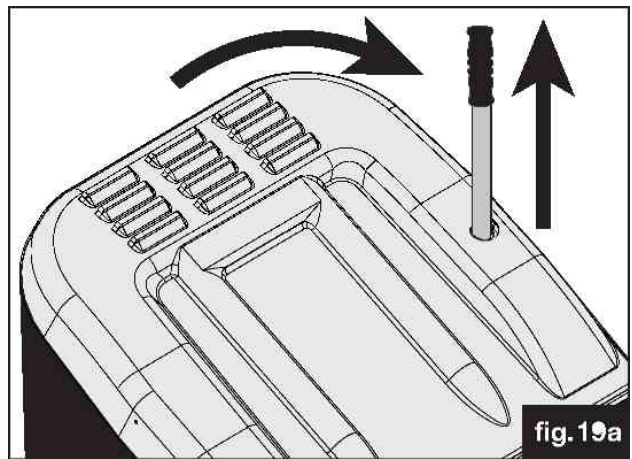
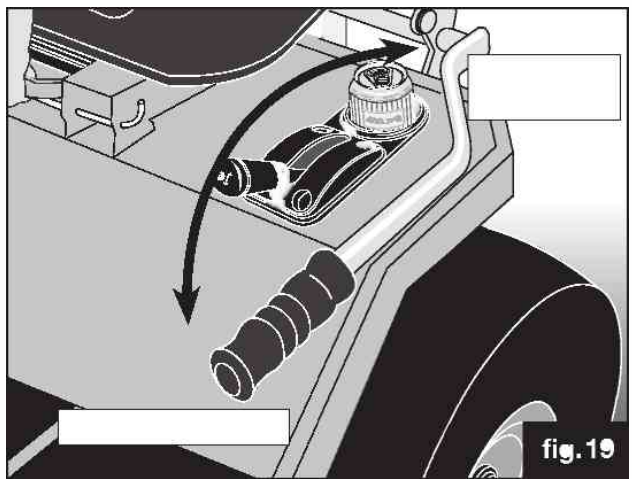
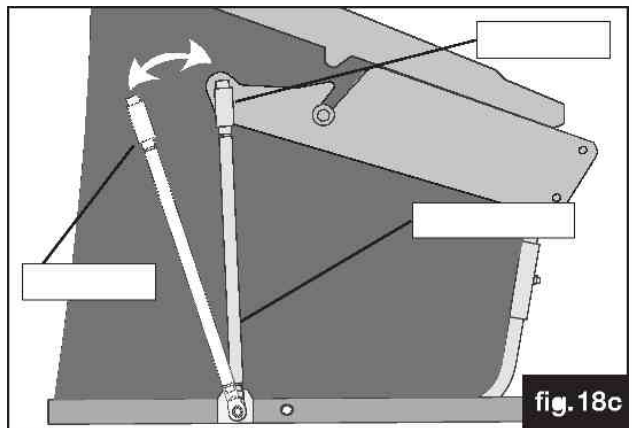

fig. 18b

Battery and Fuel (Mini tractor) (Figure 18b)

The Mini has a simple dashboard arrangement. The two red filtered squares show the charge (Left hand) and the fuel level (right hand). When the ignition is turned on the charge light is lit. The only time the charge light goes off is when there is a failure with charging. If this happens you should ring your nearest dealer.

When the fuel level is running low the fuel warning light will appear. The tractor will need to be refuelled A.S.A.P.



Operating Instructions, Powered Grass Collector

Removing and fitting the Net

(C Series fitted with Electric Net) (Fig. 21)

First turn off the engine. When removing the net, we suggest you employ the assistance of another person.

1. Partially open the PGC net (100mm (4")).
Disconnect the net rod by pulling back on the sprung locking tube and uncoupling it from the pin. The locking tube should then be attached to the securing pin. The process should be repeated on the other side.
2. Disconnect the second locking tube from its pin.
3. With one person standing on each side of the collector net, lift the net off the bag ears.
4. Reverse the above operations for fitting the net.

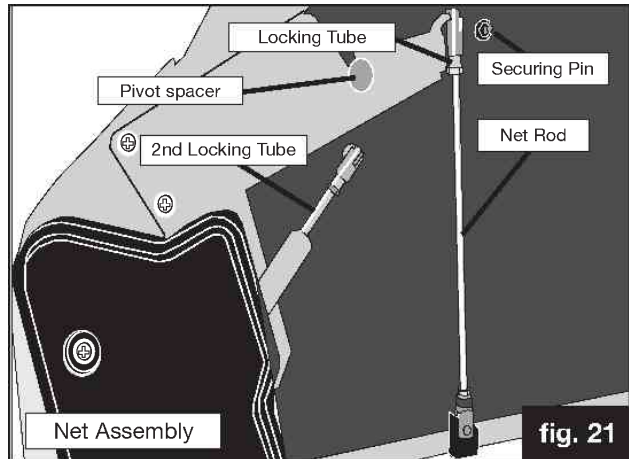

fig. 21

Removing and fitting the Net

(A Series fitted with Electric Net) (Fig. 21a)

First turn off the engine. When removing the net, we suggest you employ the assistance of another person.

1. Partially open the PGC net (100mm (4")).
Disconnect the net rod by pulling back on the sprung locking tube and uncoupling it from the pin. Repeat on the other side.
2. Undo the net locking clip (both sides), then unhook the levers from the locating pins.
3. Disconnect the Locking Tube Ball Joints.
4. With one person standing on each side of the collector net, slide the net off the locating arms.
5. Reverse the above operations for fitting the net.

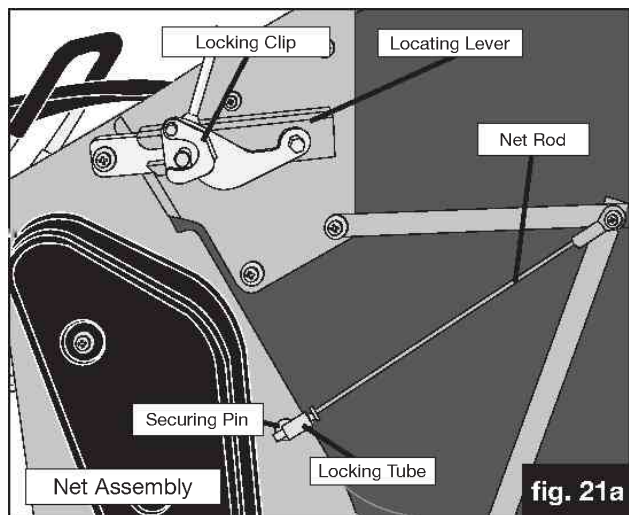

fig. 21a

PGC Connection

(Tractors fitted with Electric Net) (Fig. 22)

First turn off the engine. To connect the Powered Grass Collector (PGC) to the tractor, ensure that both are on an even surface with the locking levers on the collector facing the Lift Arms on the tractor. Lift the seat and the PTO flap so that both are resting in the upright position. Move the Collector manually to the tractor; lower the Lift Arms using the button on the dash console.

At the end of each Lift Arm you will find a Locating Lug. Slide the Channels on either side of the Powered Collector over the Lugs but do not engage the Locating Lever yet. Ensure that the Rubber Flap at the opening of the PGC locates on top of the Transmission Grass Deflector.

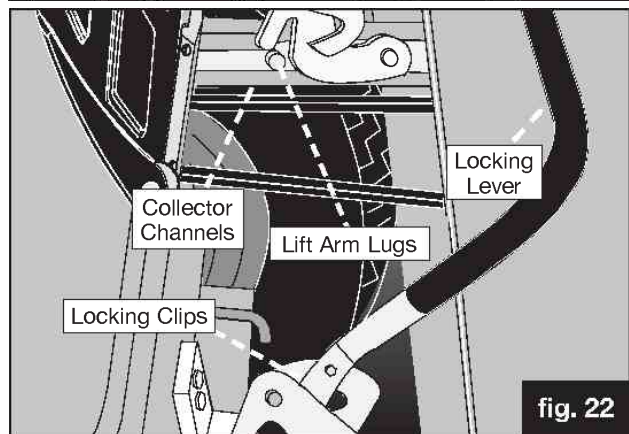

fig. 22

Net Empty Plug (where fitted) (Fig. 23)

If fitted, connect the net empty plug to the socket as shown in Fig. 23, to disconnect, reverse this procedure.

This plug **MUST BE FITTED** before attempting to use your Powered Grass Collector.

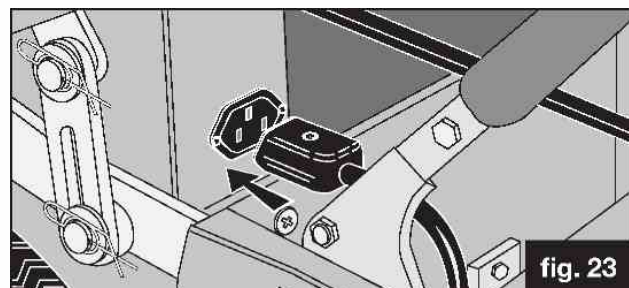

fig. 23

Using your Garden Tractor

Adjusting the sweeper height (Fig. 24)

Use the sweeper height lever to select the position appropriate to the conditions and the height of cut. TO GET THE BEST SWEEPING PERFORMANCE AND TO PRESERVE THE BRUSHES SELECT THE HIGHEST SETTING THAT WORKS – start high and adjust down until the brushes start to collect (normally the middle adjustment hole). Do not set the brushes too low – this will lead to scarifying and a very untidy finish as well as shortening brush life.

To tip cuttings

(Tractors fitted with Electric Net) (Figs. 15 & 16)

When it is full, raise the Collector to the transport position (Page 7, Fig. 15). Drive to your tipping area, reverse to the pile, then depress the PGC Net Empty Switch (Page 7, Fig. 16).

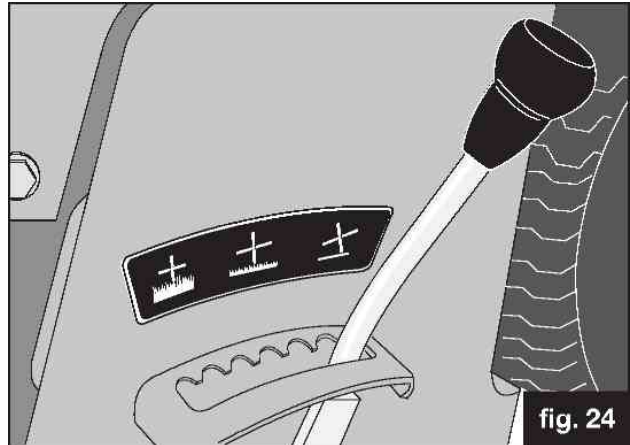

Standard grass collection

When cutting the grass and collecting follow these simple steps:

1. Always run the engine at maximum speed.
2. Lower the sweeper to the working position.
REMEMBER: TO GET THE BEST SWEEPING PERFORMANCE AND TO PRESERVE THE BRUSHES, SELECT THE HIGHEST SETTING THAT WORKS.
3. Engage the sweeper drive.
4. Engage the cutter deck drive.
5. Lower the deck to the desired height of cut.
6. Drive forward at a speed that does not cause the engine speed to drop. *REMEMBER: if the RPM display flashes below 2600rpm, there are two options: a) Reduce forward speed b) Raise the cutting height.*

Sometimes when cutting long grass or a paddock, it may be better to cut the grass and disperse the clippings directly to the ground. Alternatively remove collector net, fit the deflector accessory and spread the cut grass prior to final collection.

fig. 25

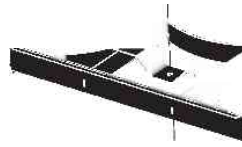
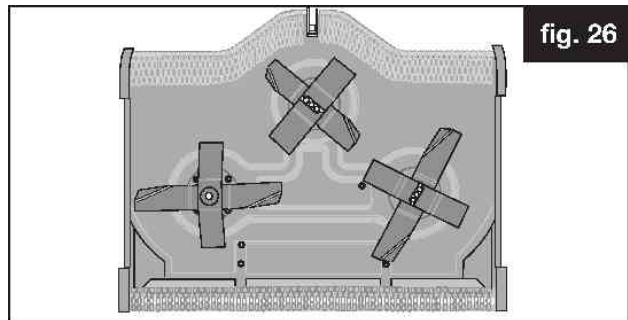

fig. 25a



fig. 26



Cutter decks

Mulching (Fig. 26a)

The Mulching cutter deck has three mulching compartments. Grass cuttings are lifted and cut several times. The small grass particles release nutrients back into the soil for healthy growth.

Mulch Mowing (Fig. 26a)

Mulching can save time, avoids creating piles of rotting cuttings and feeds your lawn. When Mulch mowing it is necessary to observe certain rules:

1. Reduce the height of the grass by no more than 1/3rd its height in each pass. If the grass has grown long make several passes to achieve the cut height you require.
2. Run the engine at maximum speed.
3. Mow often, particularly in spring and early summer. Short clippings of 25mm (1") or less decompose more quickly.
4. If an unsightly residue of cuttings is being left – increase the cutting height.
6. Vary the mowing pattern from cut to cut.
7. Always keep the underside of the cutting deck clean to ensure good grass flow.
8. Always check that the blades are sharp and in good condition – never attempt to sharpen or replace them yourself.

Belt Arrangement (Figs. 27, 28, 28a & 29)

Fig. 27 – High Grass Mulcher and Rear Discharge

Fig. 28 – Combi deck (97cm and 112cm)

Fig. 28a – Combi deck (127cm)

Fig. 29 – Twin Blade (92cm)

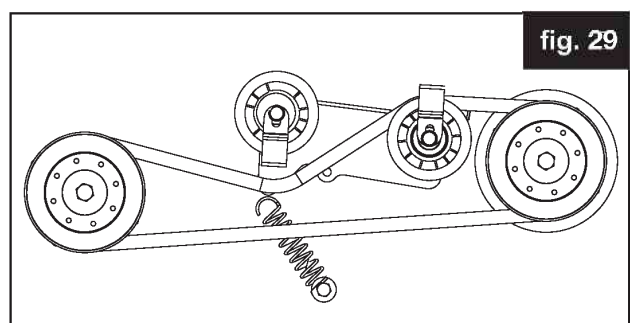
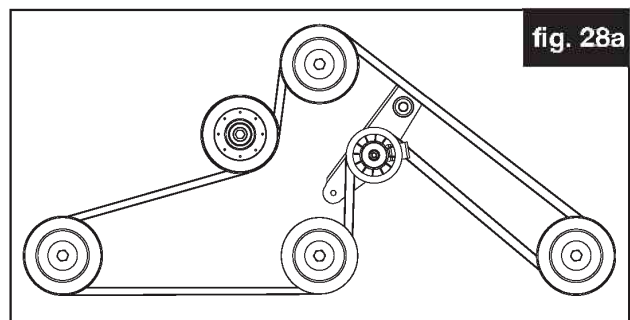
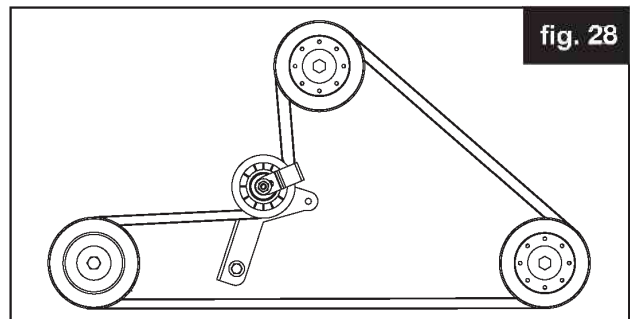
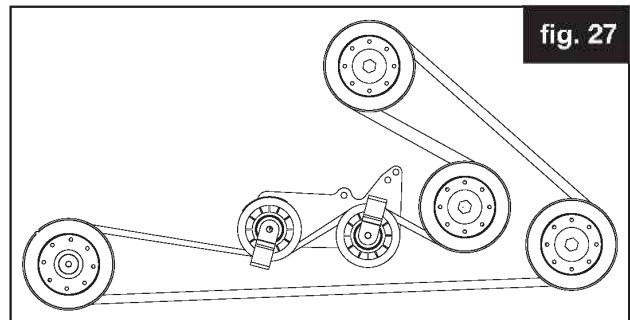
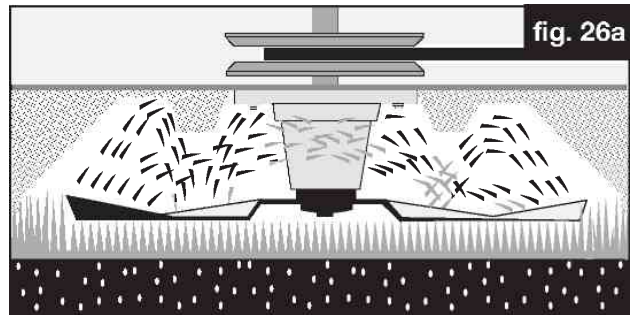

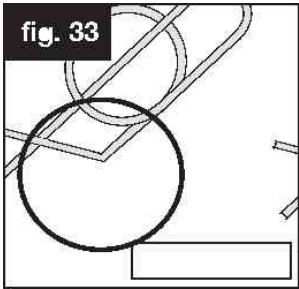
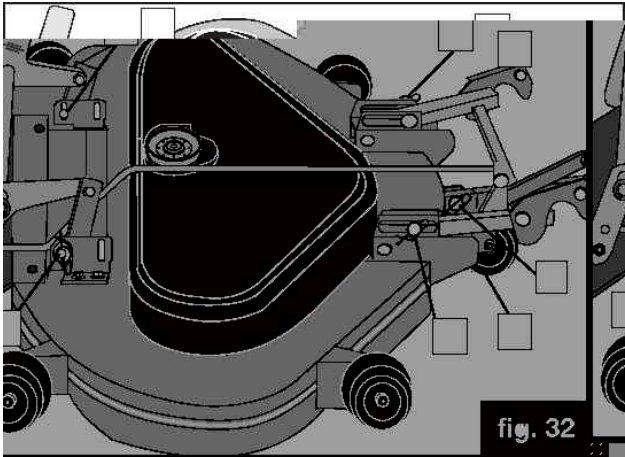
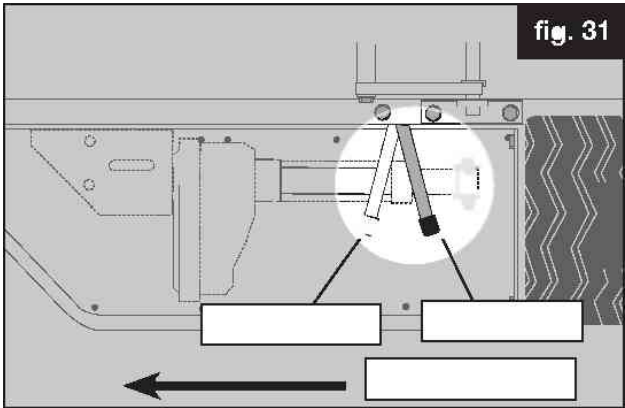
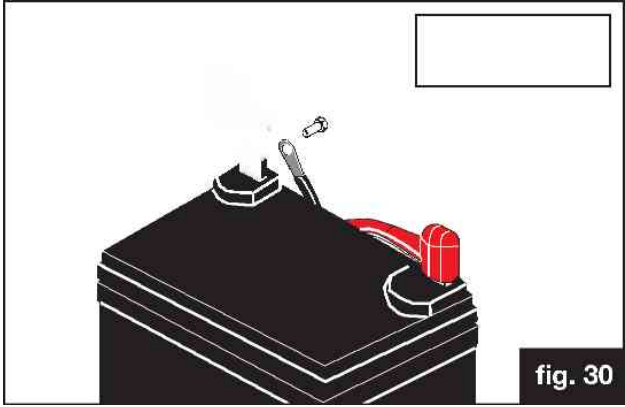

fig. 30a

Routine Maintenance

Engine to Cutter Drive Belt Tension

The correct tension of the Cutter Drive Belt is critical. If incorrectly set it can lead to engine damage and invalidate the warranty.

To check the tension put the deck in position 5 on the electric lift display.

1. Select a midway position on the belt, using a spring balance; apply a 2kg (4-5lbs) pull (Fig. 34).
2. Using a ruler or tape, measure the deflection achieved which must be 13mm (1/2"). If more, the belt tension must be increased, if less – decreased.

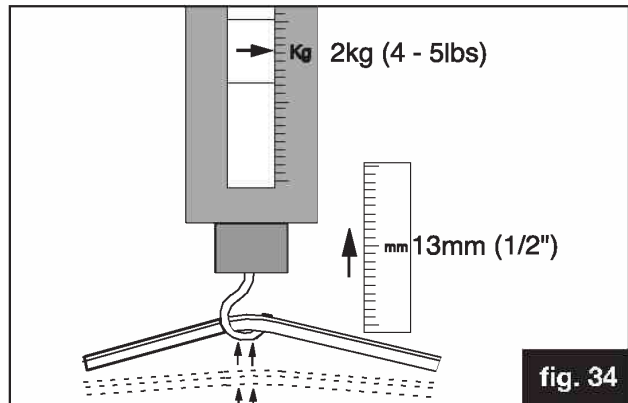

To correct the tension, follow this procedure:

1. Release the tension on the belt by pulling the Belt tension lever (page 14, Fig 31) forward.
2. Taking Care not to burn yourself on a hot Exhaust, use a 17mm long reach socket to undo the half nut.
3. Once the half nut is loosened off, use a 19mm Long reach socket to undo the deck tension adjuster. Turn anti-clockwise to tension and clockwise to un-tension.
4. Having made the adjustment, tighten the half nut and re-tension the belt with the belt tension lever-then
5. Re-check the belt tension.

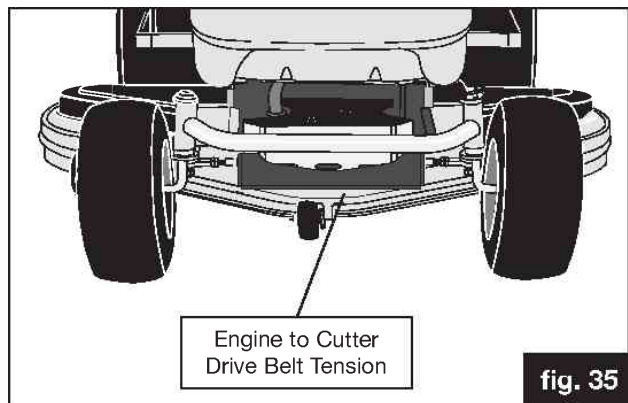

Transmission Drive Belt

The transmission drive belt is self-tensioning. When the hand brake is released and the drive belt engaged, the belt will retain its tension correctly. When the drive is dis-engaged using the hand brake the park brake engages. This setting is adjustable but should be carried out by your dealer, anyone not familiar with this setting may cause serious damage to the transmission.

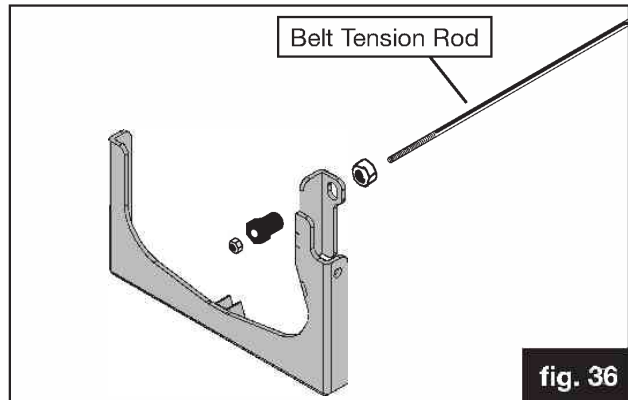

Transmission Oil Tank

(4WD models only) (Fig. 37)

This is located in the Tractor rear body and should be approximately half full when the machine is cold. This level will rise when the engine is warm as the oil expands. It should return to the half way point once the machine has cooled down. The oil should not need to be topped up in normal use. If a noticeable drop in the level occurs then your dealer should be contacted.

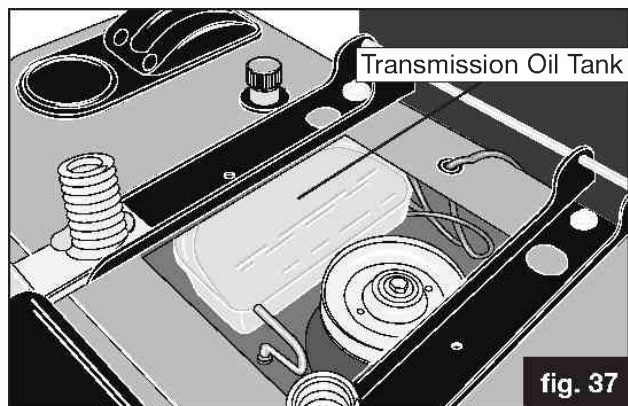

Routine Maintenance

PTO Main Drive Belt

The PTO drive belt is self-tensioning when the drive is engaged. If this belt does require any adjustment it should be carried out by your dealer; anyone not familiar with this setting may cause serious damage or even injury when using a machine with badly adjusted belts.

Accessory Drive Belt installation

(Figs. 39 & 40)

1. Lift the PTO Guard.
2. Place the drive belt over the PTO pulley of the Powered Grass Collector.
3. Feed the belt around the PTO pulley clockwise.
4. Lock the Locating Lever over the Lift Arm Lugs.
5. Check Belt Tension (19mm deflection 2kgs pressure).
6. Rotate the locking clips over the Locating Lugs.

If the belt tension is incorrect, movement of the sweeper Locking Levers on the threaded rod can adjust it. Ensure the lock nuts are suitably tightened after adjustment. Belt tension should be set in the working position.

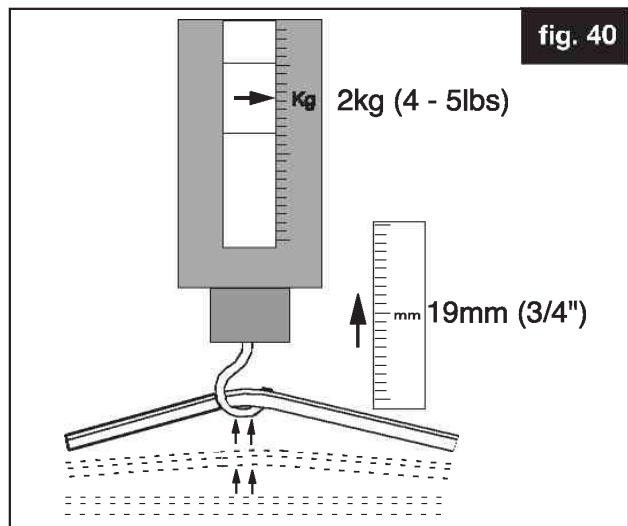
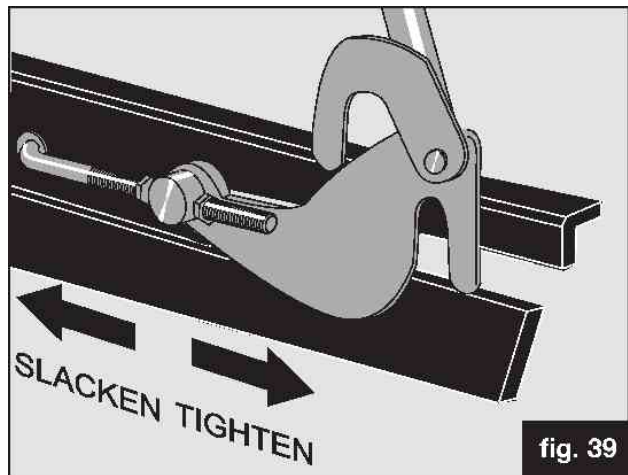
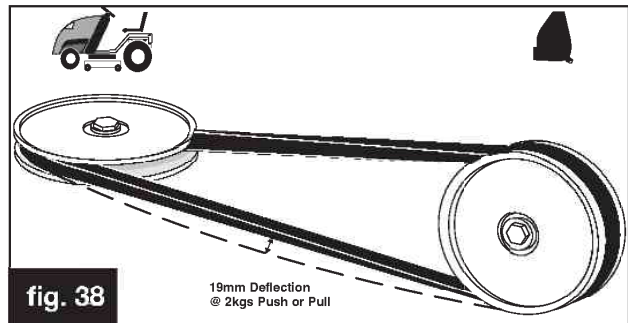

Troubleshooting (Cutting)

Cutter fails to start or cuts out when switched on

CHECK:

- ✓ Are you on the tractor? – Unless you sit on the seat, the safety switch cuts out the Cutter Deck.
- ✓ That either the Cutter Switch or the Safety Switch on the seat is not faulty – if so, call your dealer.
- ✓ Is the battery low? – The Clutch Engage Switch will only operate if the battery is well charged.
- ✓ The Engine is running.

Uneven cutting

CHECK:

- ✓ That all tyres are inflated to their correct pressures – see *Specification pages 25-27*
- ✓ That the front axle is pivoting freely.
- ✓ The deck brackets are moving freely and not locking up.
- ✓ That the deck is level from side to side and back to front (See Cutter Deck Levelling).
- ✓ That one or more of the cutter blades are not worn or damaged – if this is the case, it is necessary to call your tractor dealer.

Uneven cut (cuts shorter one side than the other)

CHECK:

- ✓ That the tyres are all inflated to the correct pressures (See above).
- ✓ That the front axle is pivoting freely.
- ✓ That the deck brackets are moving freely and not hitching up.
- ✓ That the side deck level adjustment is correct (Page 19).

Cut is uneven or untidy in one or more sectors

CHECK:

- ✓ That the Cutter Deck is levelled correctly front to back (Page 18).
- ✓ That one or more of the blades are not worn or damaged – if so, call your dealer.

The Cutter seems to lose power and the Belt slips and overheats

CHECK:

- ✓ That the Tensioner Rod is correctly applied (Page 14, Fig. 31).
- ✓ That the Cutter Belt Tension is correct (See page 15).
- ✓ That the Cutter Deck is not clogged with wet cuttings.
- ✓ That the Cutter Drive belt is not worn.

We do not recommend that customers attempt to change cutting blades themselves: remember that it is never worthwhile to have blades re-ground. It is cheaper and better to replace blades – re-grinding is likely to affect the hardening of the blade and its balance.

The Cutter Deck should be set so that it is parallel to the surface it is cutting with a maximum variation from side to side, or front to back of 3mm. Check this by placing the tractor on a hard level surface and measuring the clearance heights front to back and side to side with a steel ruler or tape, with the Cutter set one adjustment up from its lowest position.

If the Cutter Deck seems to require levelling, first check these other possible causes:

- ✓ Are the tyres correctly inflated? – If not, rectify using the figures on pages 25-27 as a reference.
- ✓ Are the Cutter Deck Hanger Brackets (Page 18, Fig. 42) moving freely or are they hitching up. To check this, lift the Cutter Deck to its highest position and lift and rock it, watching to ensure that the brackets move freely – if not, clean and lubricate.
- ✓ Is the front axle pivoting freely? – If not, it may require lubrication or adjustment.
- ✓ Is there any impact damage that has bent or distorted the Deck or Suspension Brackets (a matter for your dealer)?

Troubleshooting (Cutter Levelling)

The Cutter Deck should be set so that it is parallel to the surface it is cutting with a maximum variation from side to side or front to back of 3mm.

Levelling front to back

Check tyre pressure is correct first. If not inflate tyres.

You need two people to level the deck – one to lift the Deck while the other removes or relocates the adjuster Trunnion.

1. Ensure that the Anti-Scalp Wheels are all set to the same height – if not, rectify (Fig. 41).
2. Lower the Cutter Deck to a position one above the lowest setting – check levels with a ruler or tape.
3. Now locate the Front to Back Adjustment Rod to the right rear offside wheel, you will find the Trunnion (Fig. 42) that links the rod to the Deck Hanger Bracket. Both the Trunnion and the Rod are threaded and adjustment is achieved by rotating the Trunnion to 'in-effect' lengthen the Rod.
4. To free the Trunnion, use a 17mm spanner or socket to remove the M10 Nyloc nut and washer and push it free.
5. Rotate the Trunnion to advance it up the Rod to pivot the back of the Deck. Rotate it the other way to lift the front. Adjustment is rapid, so try one or two turns first and relocate the Trunnion and secure – then check the effect. Repeat and re-check if necessary.

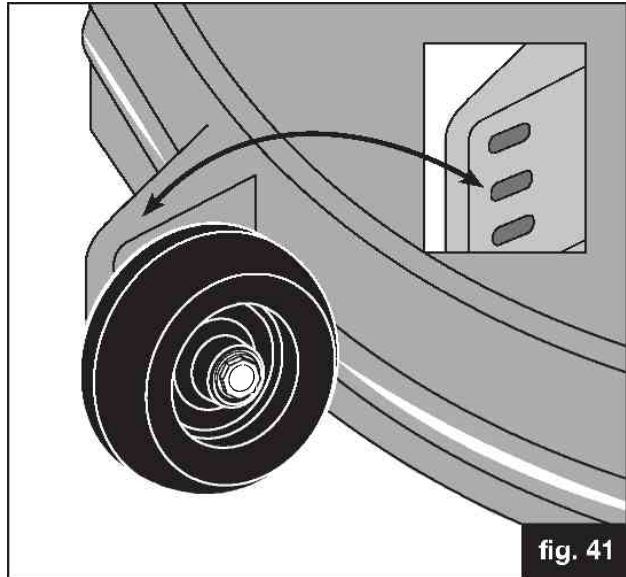

For best results, set the Anti-Scalp Wheels in the middle adjustment holes. If you are experiencing scalping, this can be minimised by setting the wheels in the lowest adjustment holes.

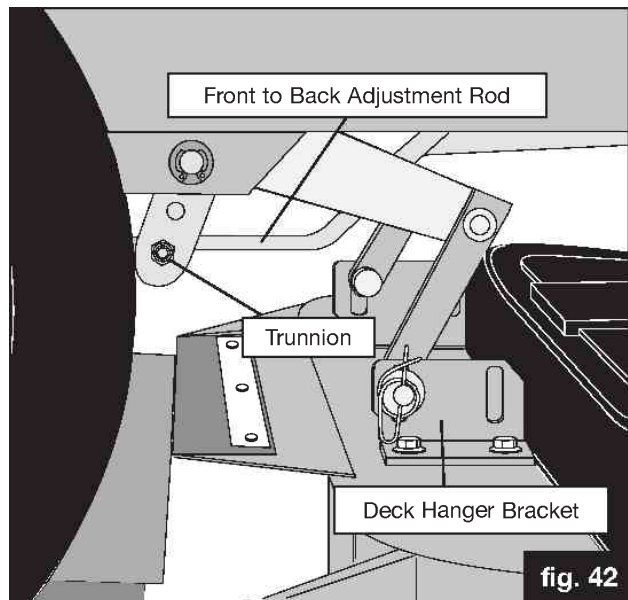

Troubleshooting (Cutter Levelling)

Levelling Side to Side

This adjustment is best done with the deck in a position three up from its lowest cut – check the level both sides and levelling is then achieved by adjusting the left side (as you are sat on the tractor) of the deck at 2 points.

OLD deck level system:

(A Series and old C Series)

Rear adjustment (Fig. 43 or 43a)

Find the Deck Level Disc (Fig. 42 or 42a) near the back (near side) wheel. This has a concentric slot in which the Deck Levelling Rod is located. Using a 13mm spanner, loosen the M8 Nyloc nut (A) securing this stud just enough to permit some movement. Now lift or depress the Deck depending on the adjustment you wish to achieve. This will move the stud up or down the disc – the higher up and nearer the centre of the disc the higher the deck. Check with your ruler or tape and having levelled the Deck at the rear, re-tighten the Nyloc nut.

Front adjustment (Fig. 43b)

Having levelled the rear of the Deck, check if the front is level. If not, find the Deck Adjustment Plate (Fig. 43b) which is forward of the Cutter Deck near the front (left) wheel. Before making adjustments, loosen the two sets of nuts and bolts (A & B). Using a 13mm spanner, loosen (upper) locknut (C). Now adjust the height by using a ratchet or spanner to turn the Nyloc nut (D) clockwise (up) to raise the Deck or anti-clockwise (down) to lower it. When level is achieved, tighten lock nut (C), re-tighten nuts and bolts (A & B). Raise and lower the cutter deck and then re-check level.

NEW deck level system:

(C350 Mini, new C Series)

Rear adjustment (Fig. 44 or 44a)

Locate the top lock nut (A) and loosen this off using a 17mm Spanner. Now wind the adjuster nut (B) either up or down using a 19mm Spanner to alter the height of the deck on the left hand side to match that on the right hand side. Use the marks on the plate as a guide as to how much to raise or lower the deck. When the deck is level at the rear tighten the lock nut securely

Front adjustment (Fig. 44b)

Locate the top lock nut (A) and loosen this off using a 17mm Spanner. Now wind the adjuster nut (B) either up or down using a 19mm Spanner to alter the height of the deck on the left hand side to match that on the right hand side. Use the marks on the plate as a guide as to how much to raise or lower the deck. When the deck is level at the front tighten the lock nut securely. Raise and then lower the cutter deck and then re-check the level. If it is still incorrect re adjust as required.

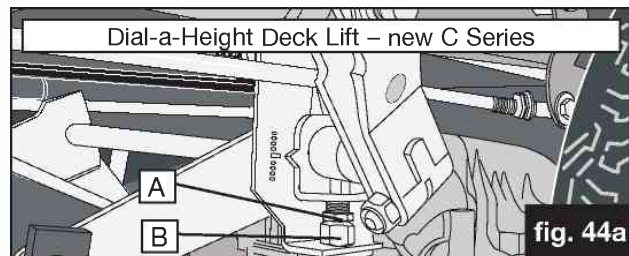
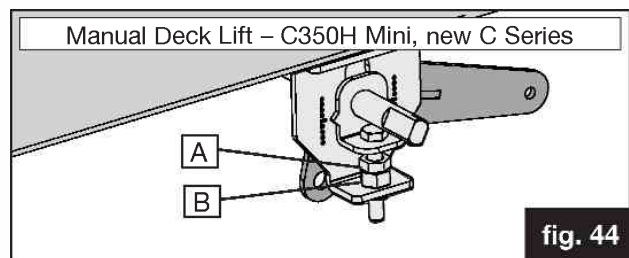
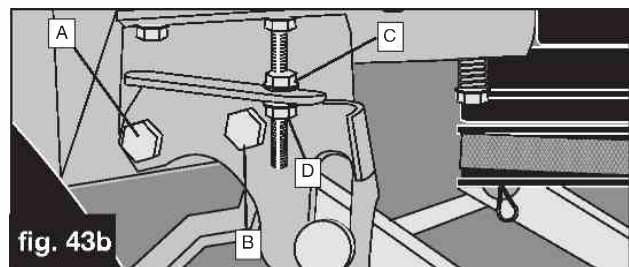
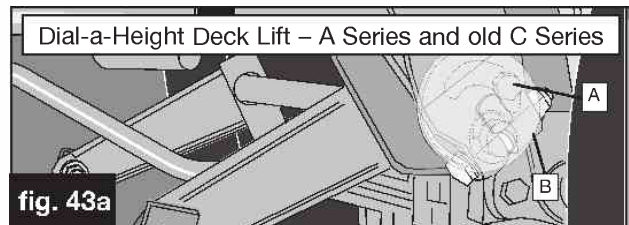
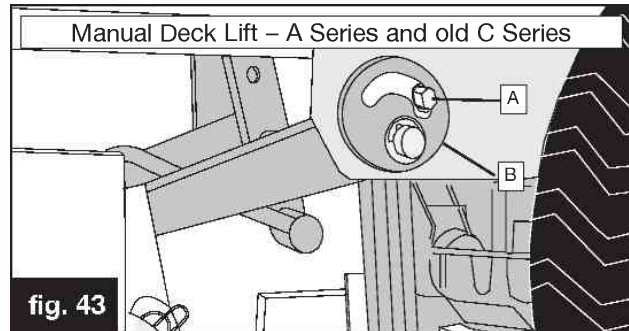

Front Adjustment

A

B

• • •

Troubleshooting (Grass Collecting)

Grass Collection (Fig. 45)

If your Collector is not picking up satisfactorily, check the following:

- ✓ The PTO lever is engaged.
- ✓ That the PTO pulley beneath the seat is turning – if not, call your dealer.
- ✓ That the Collector Belt is not reversed (if it is correct, the brush revolves against the forward direction of the tractor (Fig. 45).
- ✓ That the Brush Height Adjustment Lever is not set too high or too low.
- ✓ That there is not a build up of congealed grass on the leading edge of the Brush Guard.
- ✓ That the Brush is not clogged.
- ✓ That the Collector Belt is not slipping, if it is then adjust the tension or replace the worn or damaged belt. See Page 16.
- ✓ That the Collector net is not clogged. If so, wash or brush with a stiff hand brush.
- ✓ That the Brush is not damaged.

If you are still experiencing difficulties with collection please contact your dealer.

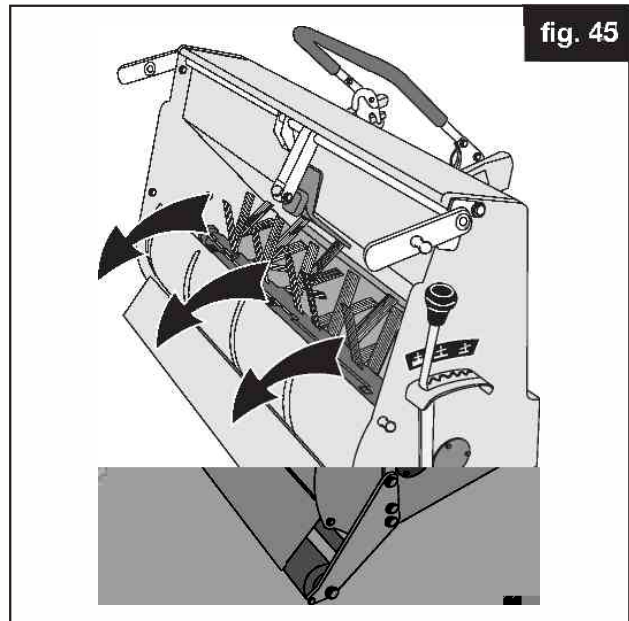

Troubleshooting (Tyres & Wheels)

Persistent flat tyres

Like all garden machinery, the most common cause of punctures are THORNS! Blackthorn, Hawthorn and Rose are usually at the bottom of the problem and will puncture any tyre not fitted with very expensive guards. There are less expensive ways to overcome this problem and it is advisable to check and avoid these possible causes:

The rim of the wheel has been damaged causing the seal on the tube-less tyre to be broken. There are two solutions:

- ✓ If the damage is significant it is necessary to order a new wheel from your dealer.
- ✓ If you have Hawthorn, Blackthorn or Wild Rose in your garden – this will puncture any tyre. It makes sense to check any area you intend to cut or drive over and to remove any branches.

If your tyres spin or lose grip, check:

- ✓ That all tyres are inflated to their correct pressures (See pages 25-27).
- ✓ Are you going too fast for the conditions?

Removal of front wheel (Fig. 46)

- ✓ Apply Parking Brake.
- ✓ Place chocks under the wheels that are to remain on the ground.
- ✓ Remove the plastic hubcap.
- ✓ Use a 19mm socket/spanner to loosen the wheel nut whilst on the ground – DO NOT REMOVE.
- ✓ Place a jack under the front axle at the jacking point Fig. 46 (on the side appropriate to the wheel that is to be removed). Jack the tractor up until the wheel to be removed is well clear of the ground.
- ✓ Remove the wheel nut and washer and keep safe.
- ✓ Taking care not to dislodge the tractor from the jack, pull the wheel off.

When the tyre is repaired, replace the wheel preferably using a new M12 Nyloc nut. Tighten to a torque setting of 5.25kg.m (38lb/ft).

Check to ensure wheel turns freely.

Removal of rear wheel (Figs. 47 & 48)

- ✓ Apply Parking Brake.
- ✓ Place chocks under the wheels that are to remain on the ground.
- ✓ Loosen the four wheel nuts.
- ✓ Place a jack under the jacking point shown in Fig. 47 (on the side appropriate to the wheel that is to be removed). Jack the tractor up until the wheel to be removed is well clear of the ground.
- ✓ Remove the wheel nuts using a 19mm spanner/socket. Once removed, keep safe and remove the wheel.
- ✓ When replacing the wheel re-tighten the nuts to 5.25kg.m (38lb/ft).

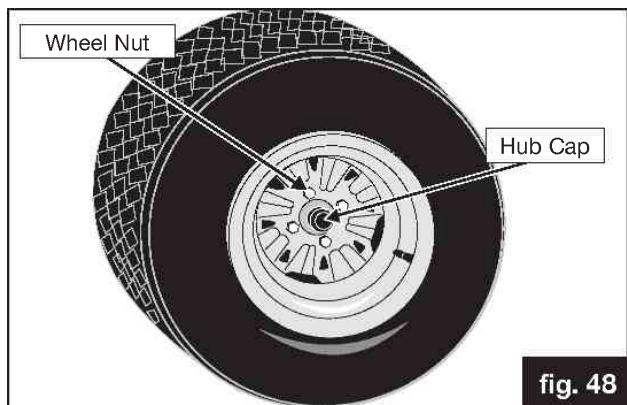
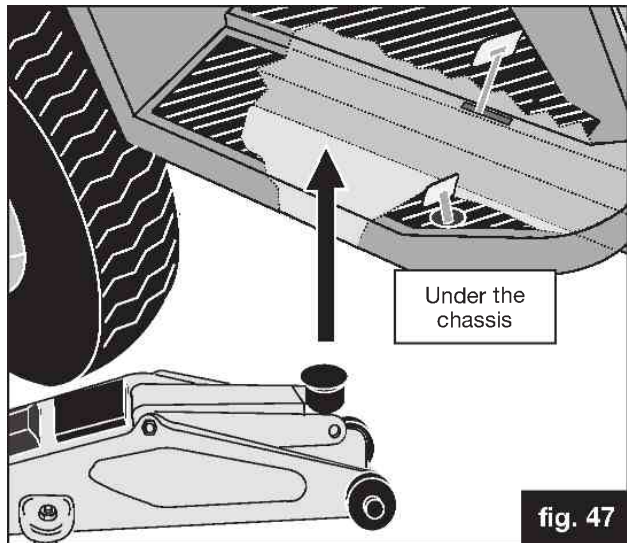
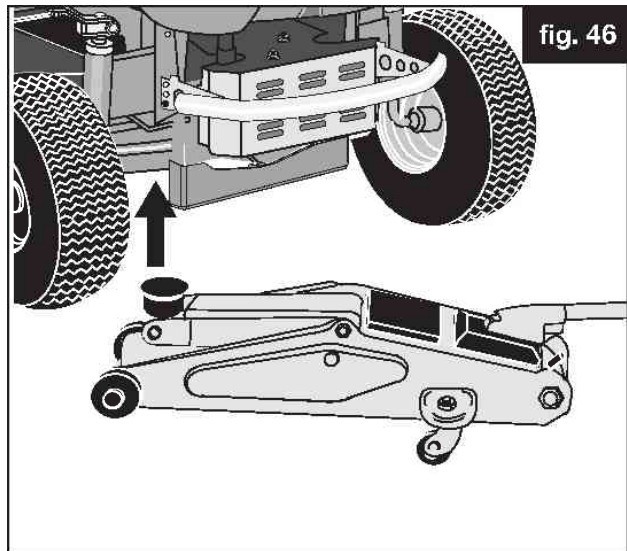

Troubleshooting (Starting & Running)

If the engine fails to turn over:

CHECK:

- ✓ That the handbrake on and that you are sitting on the seat.
- ✓ That the battery terminals are connected (Page 11).
- ✓ That fuse 2 (yellow 20amp ignition fuse) has not blown or been dislodged (Pages 22/23).
- ✓ That the battery is charged.

IF THIS IS NOT THE CASE CONTACT YOUR TRACTOR DEALER.

For fuse box location see Fig. 50.

If the engine turns over and does not start:

CHECK:

- ✓ That the fuel tank is full.
- ✓ That the outlet in the fuel tank is not blocked.
- ✓ That the Fuel Filter is not blocked (See Engine – Air and Cooling).
- ✓ That fuse 5 (red, 10amp) has not blown or been dislodged (Pages 22/23).

IF THIS IS NOT THE CASE CONTACT YOUR TRACTOR DEALER.

If the engine misfires, loses power or stalls in use:

CHECK:

- ✓ That you have not run out of fuel. To re-fuel, see Fig. 49.
- ✓ That the Air Filter Pre-cleaner is not blocked (See Engine – Air and Cooling).
- ✓ That the cooling air intakes are not blocked.
- ✓ If the ignition lights have gone off – check yellow 20amp fuse, fuse 2 on the fuse holder (Pages 22/23).
- ✓ That fuse 5 (red, 10amp) has not blown or been dislodged (Pages 22/23).

IF THIS IS NOT THE CASE CONTACT YOUR TRACTOR DEALER.

If the cutter deck fails to operate:

CHECK:

- ✓ That fuse 3 on the fuse holder (brown 7.5amp clutch fuse – A Series only; red 10amp on C Series and C350 Mini) has not blown (Pages 22/23).
- ✓ Whether you have got off the seat – the safety switch will disengage the cutter.
- ✓ If the battery has lost charge it will no longer hold the Clutch in operation.

IF THIS IS NOT THE CASE CONTACT YOUR TRACTOR DEALER.

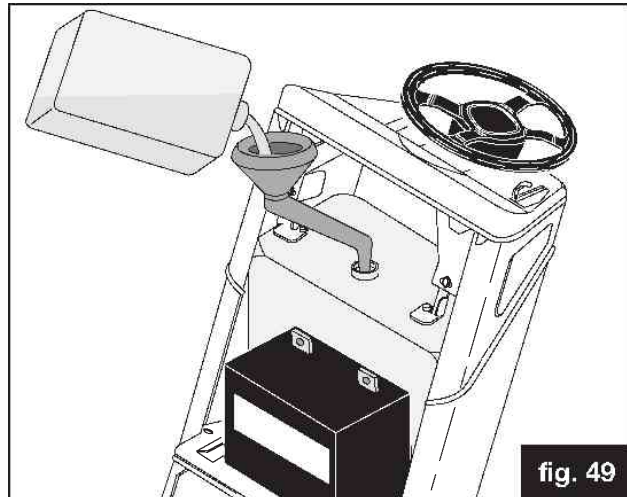

fig. 49



fig. 50

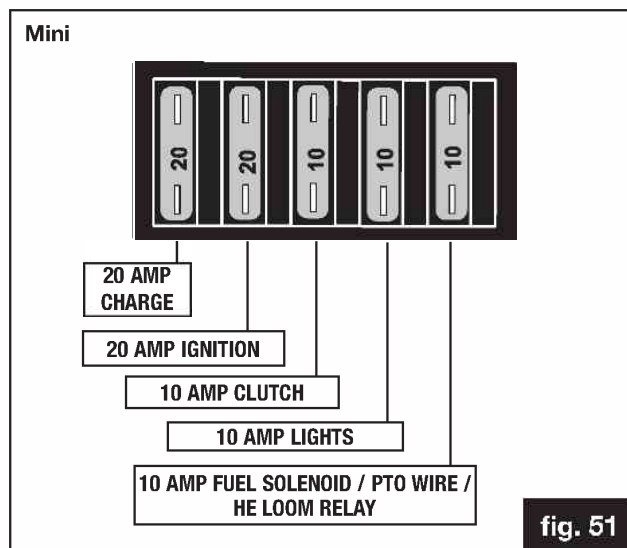

fig. 51

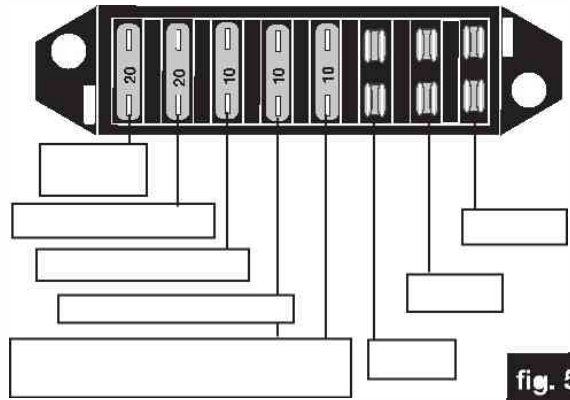

fig. 51a

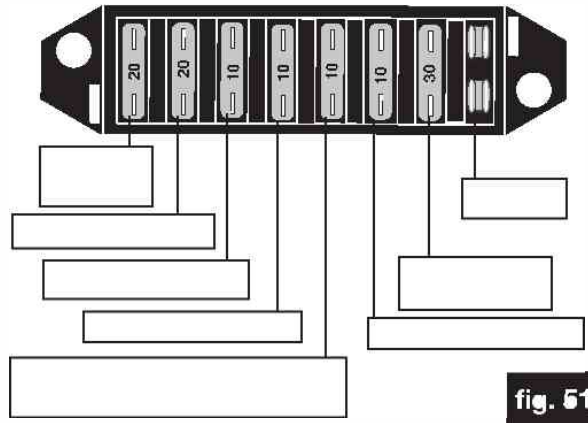

fig. 51b

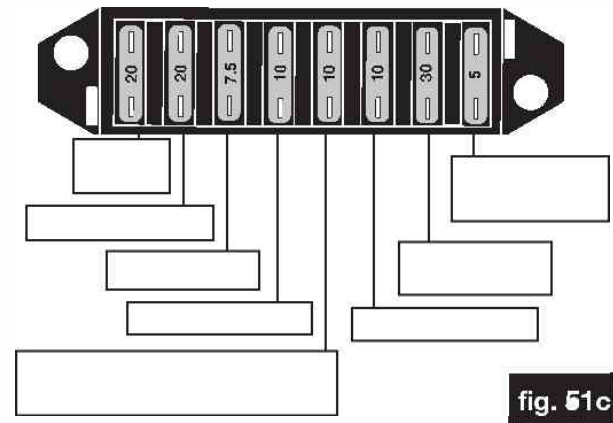

fig. 51c

Troubleshooting (Electrical) *(not applicable to Mini tractor)*

If a C appears in the Park Brake window for more than a couple of minutes: (Fig. 52).

CHECK:

- ✓ This indicates you may have a charging problem.
- ✓ Check that main charge fuse 1 has not blown, (Yellow 20amp fuse). (Page 23).

IF THIS IS NOT THE CASE CONTACT YOUR TRACTOR DEALER.

If the Tractor Display fails to light up when turned on, or the tractor doesn't start:

CHECK:

- ✓ Check fuse 2 has not blown, (yellow 20amp fuse) (Page 23).

IF THIS IS NOT THE CASE CONTACT YOUR TRACTOR DEALER.

Service Intervals: (Fig. 53)

These are preset into the PCB memory and will flash up 'S' on the park brake display before the service is due. This will be reset by your dealer. The first service for your tractor is after 50 hours of use or yearly, then every 50 hours or yearly. The service light will come on 5 hours before the service is due.

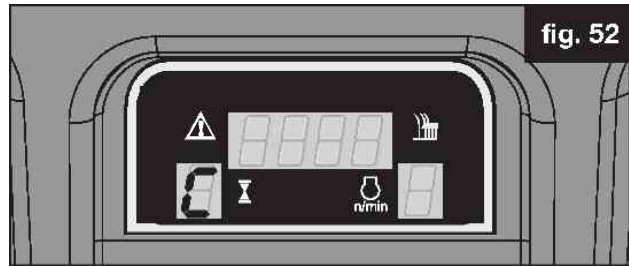

fig. 52



fig. 53

Specifications – C Series

Weight

C350H Mini	209.7 kg
C500H	229.3 kg
C600H	239.1 kg
C800H	241.2 kg
C600-4WD	244.2 kg
C800-4WD	246.3 kg
C25-4WD	265 kg

Weight

C350 Mini PGC	43 kg
C Series PGC	44.6 kg

Fuel Tank Capacity

7 litres (1.5 gallons)

PGC Capacity

255 litre (C350H Mini only)
300 litres

Transmission

Tuff Torq K46 Hydrostatic or
Peerless MST 206/536A Transaxle or

Transmission 4WD

Tuff Torq K574 & HFWD

Turning Radius

C350H Mini 142.7cm
2WD 128.0cm
4WD 152.0cm

Forward Speeds

0-6 mph

Tyre Pressures

Mini

Front: 0.7-1.0 KGF/cm (10-14 psi)
Rear: 0.7-1.0 KGF/cm (10-14 psi)

C Series

Front: 0.8-1.1 KGF/cm (12-16 psi)
Rear: 0.7-1.1 KGF/cm (10-12 psi)

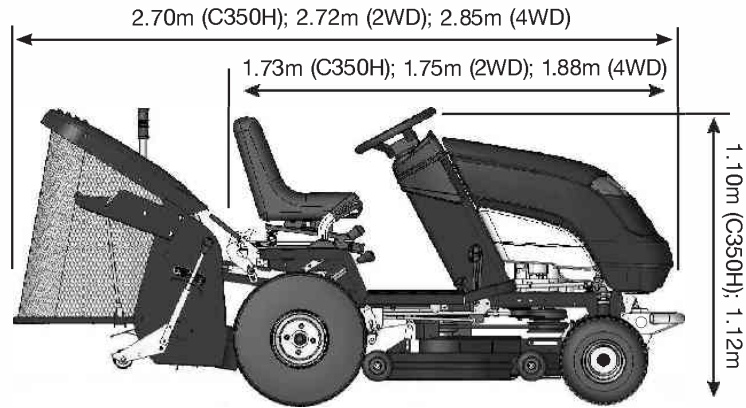
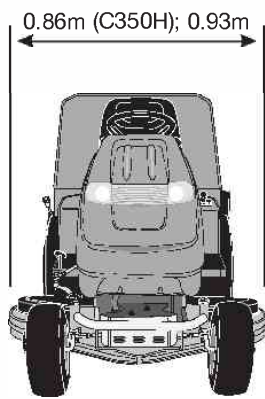

Model	Engine	Displacement	Power	Torque	Bore	Stroke
C350H Mini	Briggs & Stratton Single Cylinder INTEK	500cc	10.81kW @ 3600rpm	28.7NM	90.49mm	77.7mm
C500H	Briggs & Stratton Single Cylinder INTEK	500cc	10.81kW @ 3600rpm	28.7NM	90.49mm	77.7mm
C600H	Kawasaki 4 stroke vertical shaft, OHV, 2 cylinder	603cc	11.9kW @ 3600rpm	43.5NM	73mm	72mm
C800H	Kawasaki 4 cycle vertical shaft, OHV, 2 cylinder	603cc	13.4kW @ 3600rpm	46.0NM	73mm	72mm
C600-4WD	Kawasaki 4 stroke vertical shaft, OHV, 2 cylinder	603cc	11.9kW @ 3600rpm	43.5NM	73mm	72mm
C800-4WD	Kawasaki 4 cycle vertical shaft, OHV, 2 cylinder	603cc	13.4kW @ 3600rpm	46.0NM	73mm	72mm
C25-4WD	Kawasaki 4 cycle vertical shaft, OHV, 2 cylinder	726cc	19.4kW @ 3600rpm	57.1NM	78mm	76mm

Specifications – A Series

Weight

A25-50HE 290 kg
 A25-50HE PGC 55 kg

Fuel Tank Capacity

7 litres (1.5 gallons)

A25-50HE PGC Capacity

390 litres

Transmission

Tuff Torq K62 Hydrostatic

Turning Radius

99cm

Forward Speeds

0-7 mph

Tyre Pressures

Front: 0.8-1.1 KGF/cm (12-16 psi)

Rear: 0.43-0.7 KGF/cm (6-10 psi)

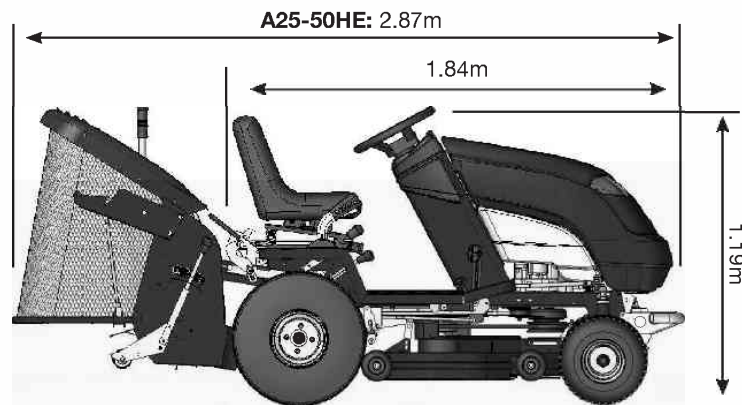
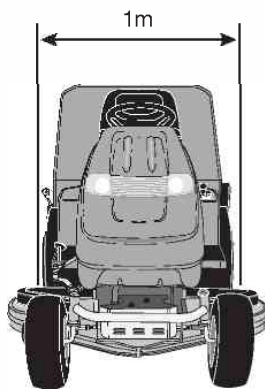

Model	Engine	Displacement	Power	Torque	Bore	Stroke
A25-50HE	Kawasaki 4 cycle vertical shaft, OHV, 2 cylinder	726cc	19.4kW @ 3600rpm	57.1 NM	78 mm	76mm

Personal Service Record

Use this page as a personal record of the service history of your garden tractor.
Ask your dealer to stamp the appropriate box at the same time as your Service Record Card.

Model Name of Dealer
Date of Purchase Serial Number
Date of Registration

1st	First Service (12 months)
DEALER STAMP OR NAME & ADDRESS	
Service Date: Hours:.....	
Dealer's Signature:	

4th	Fourth Service (48 months)
DEALER STAMP OR NAME & ADDRESS	
Service Date: Hours:.....	
Dealer's Signature:	

2nd	Second Service (24 months)
DEALER STAMP OR NAME & ADDRESS	
Service Date: Hours:.....	
Dealer's Signature:	

5th	Fifth Service (60 months)
DEALER STAMP OR NAME & ADDRESS	
Service Date: Hours:.....	
Dealer's Signature:	

3rd	Third Service (36 months)
DEALER STAMP OR NAME & ADDRESS	
Service Date: Hours:.....	
Dealer's Signature:	

6th	Sixth Service (72 months)
DEALER STAMP OR NAME & ADDRESS	
Service Date: Hours:.....	
Dealer's Signature:	

Certificate of Conformity

Manufacturer: COUNTAX Ltd.

Address: Countax House, Haseley Trading Estate, Great Haseley, Oxon, OX44 7PF

Model:	C350H Mini	C500H	C600H	C800H	C600-4WD	C800-4WD	C25-4WD	A25-50HE
Power (kW)	10.81	10.81	11.93	13.42	11.93	13.42	19.4	19.4
Engine operating speed	3600rpm	3600rpm	3000rpm	3000rpm	3000rpm	3000rpm	3030rpm	3030rpm
Engine manufacturer	Briggs & Stratton	Briggs & Stratton	Kawasaki	Kawasaki	Kawasaki	Kawasaki	Kawasaki	Kawasaki
Engine type	Petrol	Petrol	Petrol	Petrol	Petrol	Petrol	Petrol	Petrol
Mass in kg	209.7	229.3	239.1	241.2	244.2	246.3	265	278.8
Max drawbar pull (kg) at coupling hook	500	500	500	500	500	500	500	500
Max sound power level	100db(A)	100db(A)	100db(A)	100db(A)	99db(A)	102db(A)	105db(A)	105db(A)
Max rear axle weight (kg)	250	250	250	250	250	250	250	250
Type of cutting device	Cutterbar	Cutterbar	Cutterbar	Cutterbar	Cutterbar	Cutterbar	Cutterbar	Cutterbar
Std width of cutting device	76cm	92cm	107cm	122cm	107cm	122cm	122cm	127cm

Conformity assessment procedure: According to EC Noise Directive 2000/14/ec

Notified Body: Intertek Research & Performance Testing, Davy Avenue, Knowhill, Milton Keynes MK5 8NL

Standards applied: Machinery Directive – 2006/42/EC Noise Directive (2000/14/EC)

92/59/EEC using BS EN ISO 12001-2:2003 Safety of machinery. (Basic concepts, general principles for design Technical principles) and BS 294:1992 BS EN 836:1997 Garden equipment. Powered lawnmowers. Safety

The undersigned, representing the manufacturer, herewith declares the product conforms with the standards shown herewith.

SIGNED:



David Sturges
Managing Director

Date of Declaration: 30/03/11

Place of Declaration: Oxford, England

Notes

Notes

COUNTAX

Countax Limited, Countax House, Great Haseley, Oxford OX44 7PF
Tel: (+44) 1844 278 800 • Fax: (+44) 01844 278 792

An *Ariens* Company Brand