

Operating and Parts manual

RINK

Model 1005 & 1010

Serial number:

REDEXIM

Kwekerijweg 8
3709 JA Zeist
the Netherlands
T: (31)30 6933227
F: (31)30 6933228
E: verti-drain@redexim.com
www.redexim.com

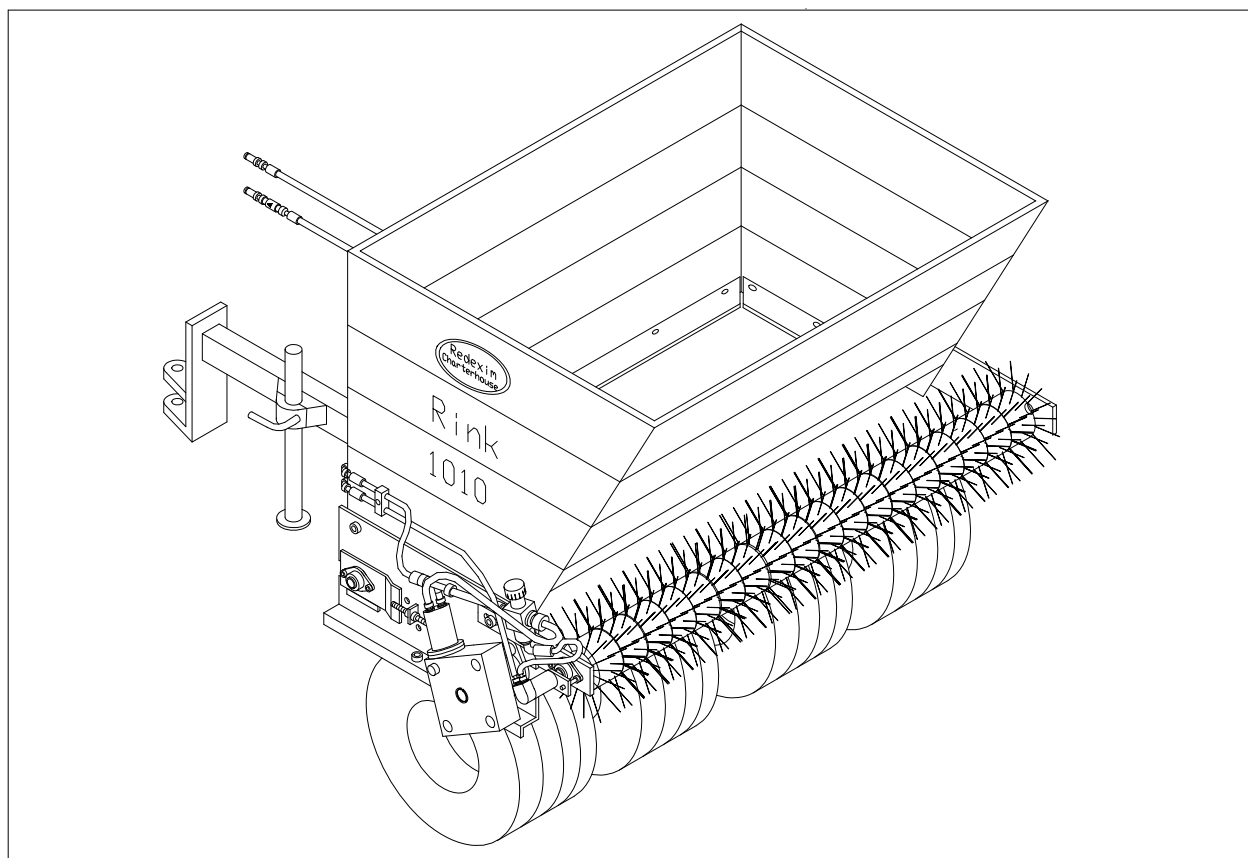
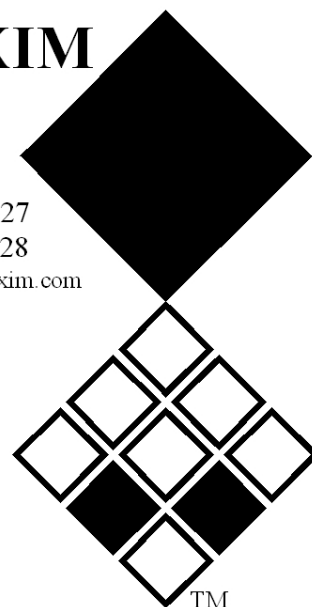

NOTE:

IN ORDER TO ENSURE THE SAFE USE AND TO ACHIEVE THE BEST PERFORMANCE, IT IS ESSENTIAL THAT THIS OPERATING MANUAL IS CAREFULLY READ BEFORE THE RINK IS USED.

TABLE OF CONTENTS

Contents	Page
Safety regulations	3, 4
Short description	5
Technical data	5
Initial Operating	6
Operation	6
* Before every ride	6
* Coupling and taking off	7
* Loading	7
* Spreading	8
* Lubricate spreader (every 50 operating hours)	9
* Oil change for conveyor belt gears (every 2 years)	10
* Axle maintenance (every 100 hours)	10
* Adjust distance between the brush and belt	11
(according to requirements)	
* Stretch conveyor belt (in case of slipping)	11
* Installing and removing the conveyor belt	12
* Stretching conveyor belt after assembly	12
* External hydraulic unit[#]	13
Spare part list	14,15,16

Technical alterations reserved.

Parts marked with [#] are only available as additional equipment.



SAFETY REGULATIONS



- (1) The **Topdresser 1005/ 1010** is built **solely for spreading small-grained**, loose material such as sand, small granular material or similar products.
Any other usage is not in accordance with the indicated use. The manufacturer **does not answer for any damage resulting from incorrect usage**. The user alone has to incur the risk.
Usage in accordance with the intended use also includes **compliance with the manufacturer's conditions of operation, maintenance and repair**.
- (2) The spreader is built according to prior art and operationally reliable; however, **the spreader could put life and limb of the operator or of third persons at risk** if it is not used, maintained and repaired by persons who are familiar with it and have been informed of the dangers.
- (3) Any person who, in the plant of the user, is responsible for the operation, maintenance and repair of the spreader, **must have read and understood** the operating instructions and, in particular, this chapter, **Safety Regulations**.
Detach the spreader from the towing vehicle during maintenance and service work.
Only use **original spare** parts from the manufacturer for repairs.
Alongside the references in these operating instructions, **the general regulations for safety and for prevention of accidents must be observed**.
When using public roads, the corresponding provisions (e.g. StVZO) will be in force.
Accompanying persons are not allowed !
- (4) A spreader may only be towed along public roads once it **holds the necessary registration**. Complete road-worthiness certificate, licensing permit and the additional safety facilities necessary for this (Lighting set, wheel chocks)[#] are obtainable on request of the customer.
- (5) The operator is obliged to **check the spreader for any external damage or failure before putting it into operation**. Any changes (including operating performance) which might affect safety must immediately be remedied. Changes to and rebuilding of the spreader (other than changes allowed by the manufacturer) are, for reasons of safety, not allowed.



SAFETY REGULATIONS



- (6) Before starting work, the operator must make himself familiar with all fittings and controls as well as their functioning.
Spreaders must be properly attached (**Risk of injuries !**)
Before driving away, check the immediate vicinity and care for a good field of vision.
- (7) **Whilst spreading is in operation, no one is allowed to enter the loading ramp.**
A label with this notice is stuck on both sides of the spreader. This notice must always be well legible and has to be replaced if damaged!
- (8) Whilst the spreader is in operation, do not enter the zone of danger of the spreader since rotating parts and foreign flying particles might cause any injuries.
- (9) Adjusting and repair work on axle (wheel bearings, tyres) must only be undertaken by properly trained and authorised personnel.
- (10) Before starting work on the hydraulic system, it is important that it is without pressure.
The hydraulic hose pipes must be regularly checked and replaced if damaged or worn out. The replacement hose pipes must conform with the manufacturer's technical requirements.
- (11) The authorized supporting load on the towing vehicle should be noted.
- (12) A sound level of 74 dB (a) is emitted in the immediate vicinity of the brush roller on the Topdresser 1005/1010.

Used oil damages the environment; please dispose of carefully

SHORT DESCRIPTION

The Topdresser 1005/ 1010 is used for spreading small-grained, loose material, such as sand, small granular material or similar products. The spreading equipment of the Topdresser is driven by a gear box with hydraulic motor for conveyor belt and a separate hydraulic motor for the brush roll. The number of revolutions of the hydraulic system for the conveyor belt can be continuously adjusted by means of a flow divider. Spreading density or spreading amount can be determined by the spreader speed and conveyor belt speed.

Technical Data

Dimensions	<u>1005</u>	<u>1010</u>
Lengt	1.10 m (44")	1.87 m (74 “)
Width	1.74 m (66 “)	
Height	1.00 m (40")	1.30 m (51”)
Loading capacity	0.75 m ³ (0.98 cu yd)	
Weights		
Authorized total weight	1700 Kg (3740 lbs)	1700 kg (3740 lbs)
Authorized axle load	--	1300 kg (2860 lbs)
Authorized supporting load	--	400 kg (880 lbs)
Empty weight	approx. 190 kg (420 lbs).....	270 Kg (600 lbs)
Spreading width	1.50 m (59”)	
Tyre equipment	3-point linkage (no tyres)	4 Swing tyres Trelleborg Garden Slick 18x9.50-8
Tyre pressure	--	0.65 bar (9 PSI)
Speed limit	30 km/h (19 mph)	
Towing capacity	30 HP, Min 1200 Kg (2600 lbs) lift capacity	min 13 Kw (16HP)
Spreading amount	continuously adjustable	
Hydraulic connected load		
Minimum conveying capacity towing vehicle		12 l/min (3.1 US gal/min)
Minimum pressure towing vehicle		70 bar (980 PSI)

The typeplate is fastened onto the front right-hand side of the spreader



INITIAL OPERATING

- * **Should the spreader be used on public roads**
(German law: only possible with licensing certificate and registration)

- Attach license plate to plate holder at the left-handed rear side.
- Check lighting set[#].

- * **After the first ride with a full load**

- Retighten wheel nuts.
- Check wheel hub clearance and have it adjusted, if necessary.
- Test tyre pressure.

OPERATION

Before every ride

- Check for any externally recognizable failures or damage and repair them.
- Check tyre pressure.
- Check lighting[#].
- Check conveyor belt tread, reset if necessary. Conveyor belt must not graze the sides.

OPERATION

Coupling and taking off

- Attach spreader to towing vehicle.
- Carry out hydraulic connection:
 - Pressure pipe positioned below, return pipe above, Oil circulation is required.
In the factory, the hydraulic system was filled with the hydraulic liquid CG46.
- With External Oil Supply[#], mount the plug-on pump on the PTO driver on the tractor and secure against slippage using the mounted torque support.
(PTO speed 450 rpm).

To ensure optimum operation, the oil temperature should have reached a temperature of around 25°C before starting work (see viewing window at the oil tank). Check the oil level before starting work (centre of the oil viewing window).

- Plug the seven-pole plug[#] into towing vehicle.



Hydraulic hoses in such a way that they do not drag to the ground or chafe at the towing vehicle.

Taking off the spreader is carried out in an analogous way.

Loading

- Pay attention to the desired maximum ground pressure.
- When loading, pay attention for the authorized total weight.

SPREADING

Controls:



The brush roller speed can only be controlled by the tractor revs.

1 Regulator for setting the speed of the conveyor belt:

Scale distribution 0 to 10

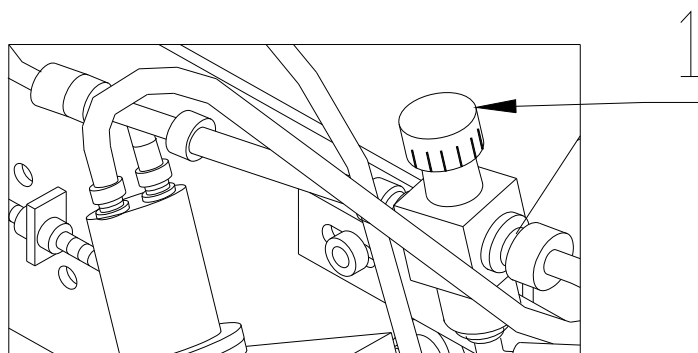

Adjusting spreading thickness:

The spreading thickness (mm) is dependent on

- the speed of the towing vehicle
- the speed of the conveyor belt (regulator)

Set the required spreading thickness on a firm surface before starting work.

Set the controller for the conveyor belt speed to the required value.

Lubricate spreader (every 50 operating hours)

Lubricate with multi-purpose grease:

- 1 Bearings on both sides of the brush roll**
- 2 Bearings on both sides of the rear conveyor shaft**
- 3 Bearings on both sides of the front conveyor shaft**
- 4 Bearings on both sides of the drive axle**

Bearings without a lubricating nipple require no greasing.

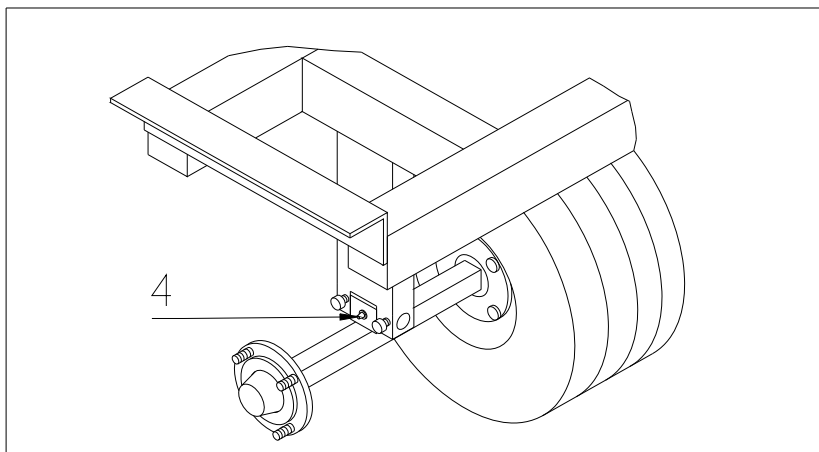
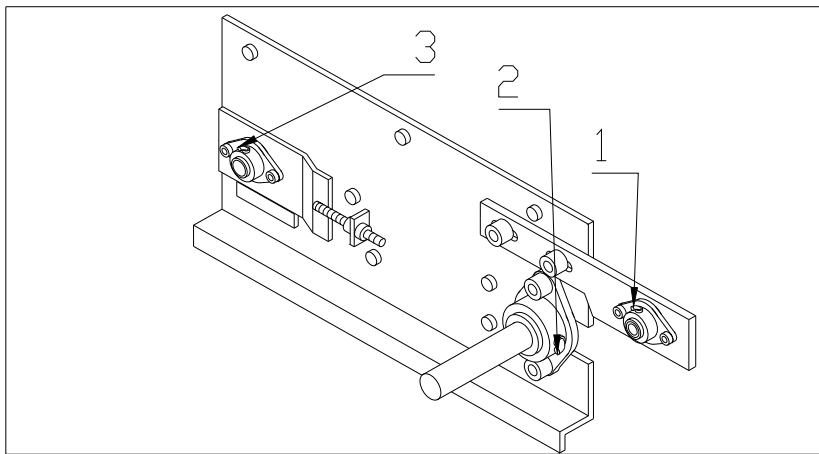

REPAIR AND MAINTENANCE

Oil change for conveyor belt gears (every 2 years.)

- Unscrew filler screw (1).
- Loosen drain plug (2) from the below inside area and drain off oil.
- Screw on drain plug with new gasket.
- Add 0.6 l Oil **SAE 120 to 140**.
- Screw on filler screw with the new gasket.

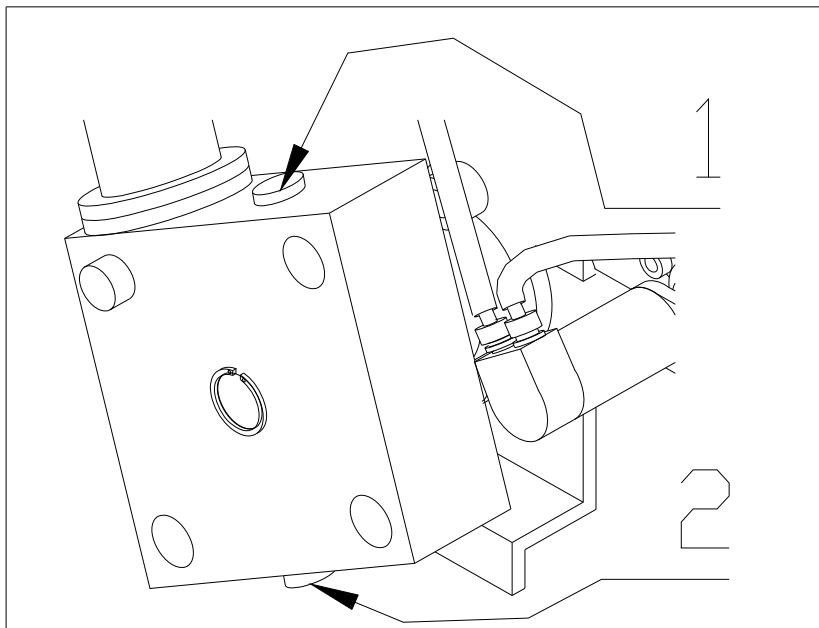

Axle maintenance (every 100 operating hours)



Maintenance work on the axle should only be carried out by fully trained and authorised personnel.

- Retighten wheel nuts.
- Check wheel hub clearance and have it adjusted, if necessary

REPAIR AND MAINTENANCE

Adjust distance between the brush and belt (according to requirements)

- Loosen the two screws (1) on each side of the brush roll.
- Move the brush roll until it slightly contacts the conveyor belt.
- Retighten screws (1).

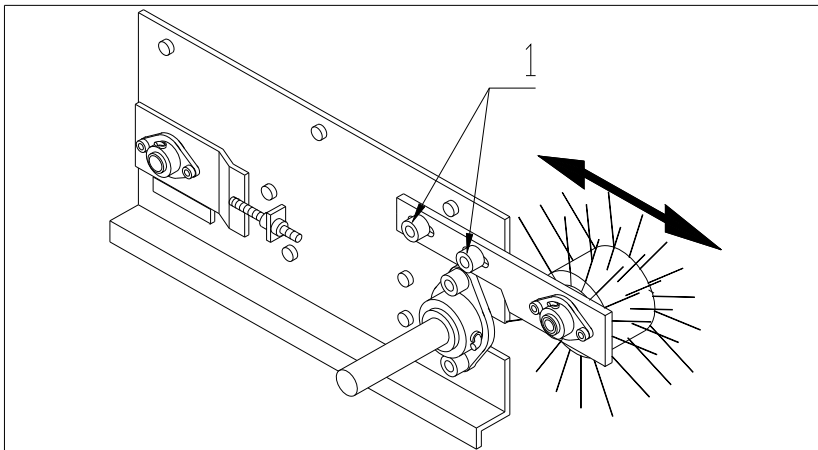

Stretch conveyor belt (in case of slipping)

- Loosen counternut (1).
- Turn nut (2) once clockwise.
- Tighten counternut.



Excessive stretching can reduce the life span of the conveyor belt.

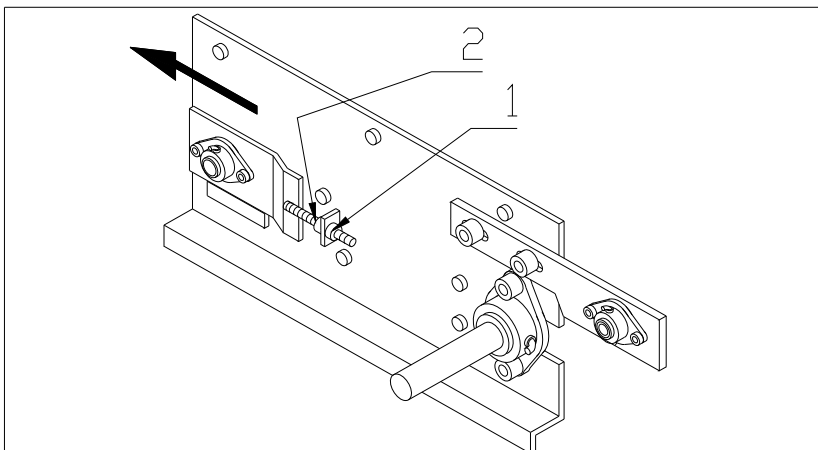

REPAIR AND MAINTENANCE

Installing and removing the conveyor belt

- Loosen screws on both sides (1) and remove the chassis.

- Remove the brush roller by loosening the screws (2).
- Release the tension on the conveyor belt on both sides (3).
- Remove the bearing on the right seen in the direction of travel (4).
- Pull away the side element (5) with tension bearing (6).
- Remove the conveyor belt.

The reassembly takes place in reverse order.

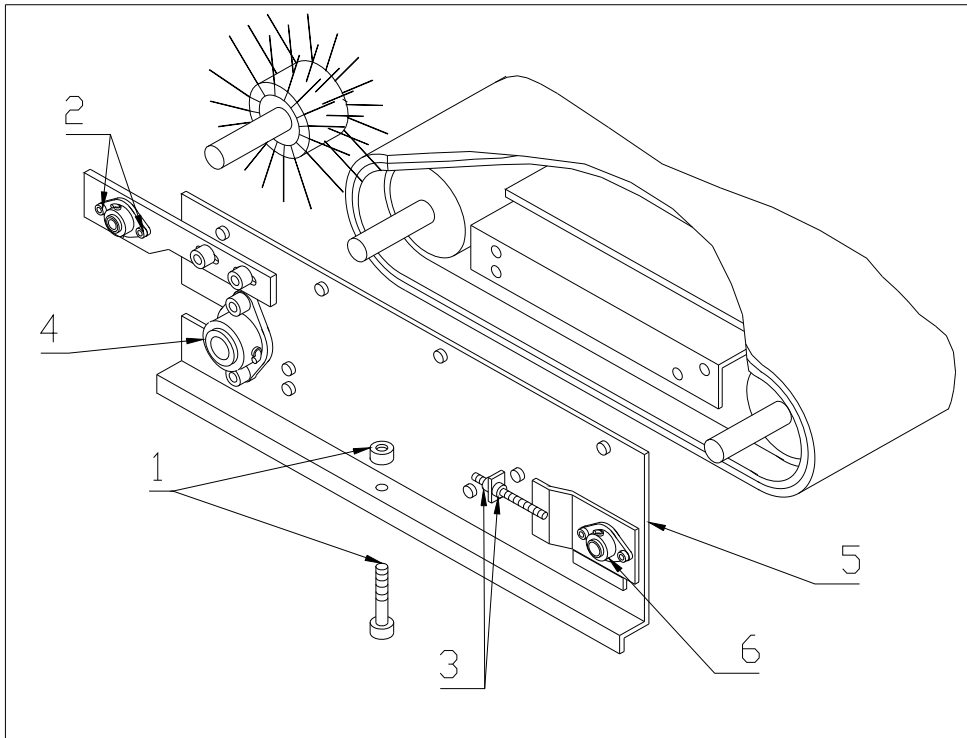

Stretching conveyor belt after assembly

- Tension the conveyor belt on both sides evenly using the two tension screws until the marked length is stretched to 487 mm [19.17"](distance between centres).
- Allow the conveyor belt to run in for approx. 30 minutes until it runs centrally.

The conveyor belt should not graze the sides. If readjustment is necessary increase tension on the side which is doing the grazing.

Too much tension will reduce the life span of the conveyor belt.

REPAIR AND MAINTENANCE

External hydraulic unit[#]

Oil change for the hydraulic pump (every 100 operating hours)

- Unscrew filler screw (1).
- Loosen drain plug (2) and drain off oil.
- Screw on drain plug with new gasket.

- Add oli **SAE 90** right up to the level of the control screw (3).
- Screw on filler screw with new gasket.

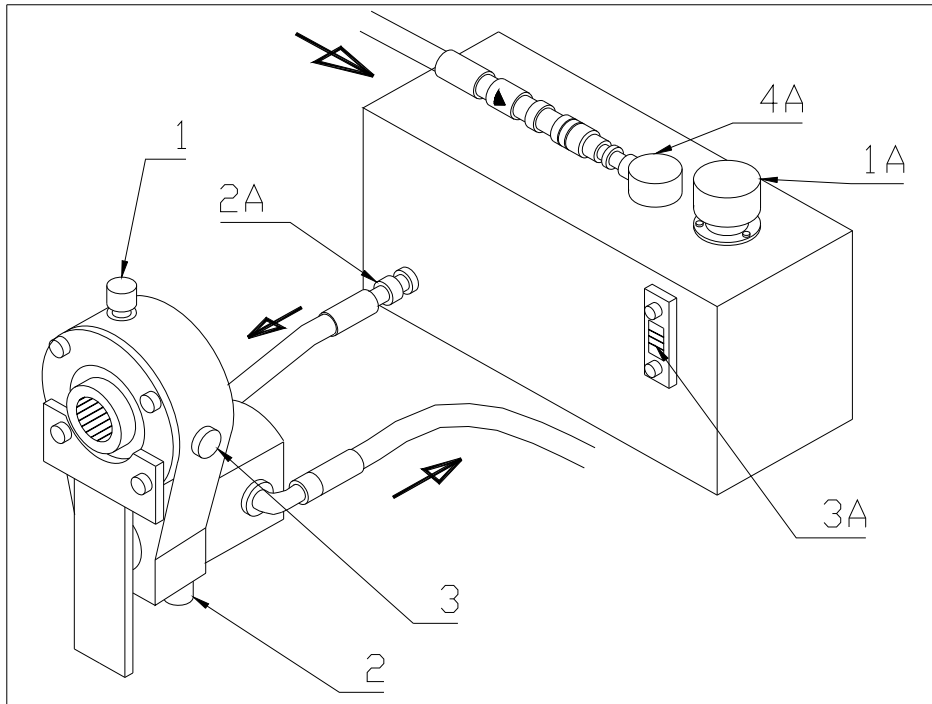

Oil change for the hydraulic tank (according to requirements)

- Unscrew the filling nozzle (1A).
- Release the suction hose (2A) and drain off the oil.
- Screw the suction hose back into place.
- Top up with **Bio-Hydraulic oil CG 46** until the level reaches the centre of the viewing window (3A).
- Screw the filling nozzle back on.

Please note:



This is a closed hydraulic circuit. In order to prevent the ingress of contaminants, the runback filter (4A) must be replaced every 100 operating hours.

Parts list

RINK 1005/ 1010

(Only most important parts are mentioned)

Ordering spare parts

To ensure that your spare parts order can be processed quickly, always specify the following data when ordering.

- Chassis number / Ident. number
- Model (year of construction if available)
- Part number from respective spare parts list
- Designation
- Order number

Ordering example: 529413 1994 13 Conveyor belt 10524

Chassis number	Model	Part no.	Designation	Order no.
----------------	-------	----------	-------------	-----------

