

## **MULTI-SEEDER 1200-1600-2100**



Translation of the original user manual



2431 English 924.120.002



Kwekerijweg 8 | 3709JA | Zeist | The Netherlands |

T: +31 (0)306 933 227

E: [redexim@redexim.com](mailto:redexim@redexim.com)

W: [www.redexim.com](http://www.redexim.com)

# EU – DECLARATION OF CONFORMITY



**We,**

Redexim Handel- en Exploitatie Maatschappij B.V.  
Kwekerijweg 8  
3709 JA Zeist, The Netherlands

**declare that this “EU - DECLARATION OF CONFORMITY” is issued under our sole responsibility and belongs to the following product:**

**MULTISEEDER WITH MACHINE NUMBER AS INDICATED ON THE MACHINE AND IN THIS MANUAL,**

**to which this declaration refers, complies with stipulation of:**

**2006/42/EC Machinery Directive**

**and with the standards:**

- **ISO 12100-1:2010** Safety of machinery - General principles for design - Risk assessment and risk reduction
- **ISO 13857:2019** Safety of machinery - Safety distances to prevent hazard zones being reached by upper and lower limbs
- **ISO 4254-1:2015** Agricultural machinery - Safety - Part 1: General requirements
- **ISO 4254-9:2018** Agricultural machinery - Safety - Part 9: Seed drills

Zeist, 03-01-2022

A handwritten signature in blue ink, appearing to be 'C.H.G. de Bree', written over a horizontal line.

**C.H.G. de Bree**

**Redexim Handel- en Exploitatie Maatschappij B.V.**

## UK – DECLARATION OF CONFORMITY



**We,**

Redexim Handel- en Exploitatie Maatschappij B.V.  
Kwekerijweg 8  
3709 JA Zeist, The Netherlands

**declare that this “UK - DECLARATION OF CONFORMITY” is issued under our sole responsibility and belongs to the following product:**

**MULTISEEDER WITH MACHINE NUMBER AS INDICATED ON THE MACHINE AND IN THIS MANUAL.**

**to which this declaration refers, complies with stipulation of:**

**S.I. 2008 No. 1597 HEALTH AND SAFETY The Supply of Machinery (Safety) Regulations 2008**

**and with the standards:**

- **ISO 12100-1:2010** Safety of machinery - General principles for design - Risk assessment and risk reduction
- **ISO 13857:2019** Safety of machinery - Safety distances to prevent hazard zones being reached by upper and lower limbs
- **ISO 4254-1:2015** Agricultural machinery - Safety - Part 1: General requirements
- **ISO 4254-9:2018** Agricultural machinery - Safety - Part 9: Seed drills

Zeist, 03-01-2022

A handwritten signature in blue ink, appearing to read 'C.H.G. de Bree'.

**C.H.G. de Bree**

**Redexim Handel- en Exploitatie Maatschappij B.V.**



## FOREWORD

Congratulations with the purchase of your Multi-Seeder. To ensure long and safe use of this Multi-Seeder, it is of major importance to all users to read and understand this user manual. Operation of this machine is not safe without full knowledge of the content of the manual.

The Multi-Seeder is not an independently operating machine. The user is responsible for using the appropriate tractor. The user must also check the tractor/Multi-Seeder combination for safety aspects, such as noise level, adequate user instructions and any risks.

The Multi-Seeder is solely intended for use on lawns and other areas where grass could grow.

On the next page you will first find the general safety instructions. Every user must know and apply them. After this, a registration card is included. This card should be returned for handling any future claims.

This user manual offers many numbered instructions. An  symbol indicates a safety instruction. A  symbol indicates a tip and/or note.

At the time of publishing all information and technical specifications provided are the most recent. Design specifications to the design of the machine may be changed without prior notice to the owner of the Multi-Seeder.

This document is a translation of the original user manual.  
Original user manual (Dutch language) is available on request.

## GUARANTEE CONDITIONS

THIS MULTI-SEEDER COMES WITH A GUARANTEE FOR DEFECTIVE MATERIALS. THIS GUARANTEE IS VALID FOR A PERIOD OF 12 MONTHS FROM THE PURCHASING DATE. MULTI-SEEDER GUARANTEES ARE SUBJECT TO THE "GENERAL CONDITIONS FOR SUPPLY OF PLANT AND MACHINERY FOR EXPORT, NUMBER 188", PUBLISHED UNDER THE AUSPICES OF THE UNITED NATIONS ECONOMIC COMMISSION FOR EUROPE.

## REGISTRATION CARD

For your own information, please complete the table below:

Serial number of machine	
Dealer name	
Purchasing date	
Remarks	

# ! SAFETY INSTRUCTIONS !

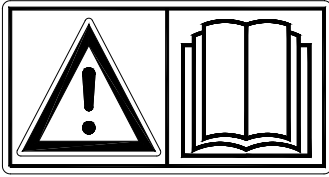

Figure 1

The design of the Multi-Seeder allows for safe use. Safe use is only possible when the user fully understands the safety instructions given in this manual.

**Read and understand** (Figure 1) the manual before working with the Multi-Seeder.

Not using the machine as described in the manual may lead to injury and/or damage to the Multi-Seeder.

## INTENDED USE OF THE MACHINE AND USER OBLIGATIONS

The Multi-Seeder is solely intended for use on lawns and other areas where grass could grow. Any other use is considered to be incorrect use. The manufacturer does not accept any liability with regard to damage resulting from incorrect use; all resulting risks are the responsibility of the user. Correct use also includes following the manufacturer's instructions for use, maintenance and repair.

The Multi-Seeder was constructed according to the latest technological knowledge and is safe to use.

All persons whom the owner assigns to operate, maintain or repair the Multi-Seeder must read and completely understand the operating manual and in particular the **Safety Instructions**

Any changes of the Multi-Seeder (including its functioning) that may affect its safety must be corrected immediately.

Every time before using the Multi-Seeder, the user is **obliged** to inspect it for **visible damage and defects**.

If any **modifications** have been made to the Multi-Seeder, the present CE/UKCA certificate becomes null and void and the person who made the modifications should **himself** is responsible for a new **CE/UKCA certificate**.

The user is responsible for a **safe tractor/Multi-Seeder combination**. **This unit must be tested** in terms of noise, safety and ease-of-use. In addition, user's instructions must be prepared.

Wear suitable clothing. Wear sturdy shoes with a steel tip, wear long trousers, do up long hair and wear no loose clothing.

In addition to the instructions in this user manual, the generally applicable regulations with respect to safety and working conditions must be observed.

For use on public roads the relevant traffic rules also apply.

Transport of persons is **not** permitted!

## REQUIREMENTS FOR THE ENVIRONMENT AND TOWING MACHINES

Before using the Multi-Seeder, inspect the area to be treated. Remove any loose obstacles from the field.

Always use the Multi-Seeder in combination with the appropriate tractor as described in the technical data.

Do not use the Multi-Seeder when it is dark, during heavy rain/storms or on slopes with a gradient of more than 20 degrees.

## REQUIREMENTS DURING MAINTENANCE, REPAIR AND ADJUSTMENT

Maintain a repairs record.

When carrying out any maintenance or repair activities, make sure to use original Multi-Seeder parts only. This will ensure safety of the machine and its user.

There is a risk of injury for the user and third parties if the machine is operated, maintained or repaired by improper persons. **This must be avoided!**

Only authorised technical personnel may carry out adjustments and repairs to the Multi-Seeder.

When carrying out maintenance activities, adjustments or repairs make sure the Multi-Seeder is stable and can't move unintentionally to prevent it from sinking/riding/sliding away.

Used oil / grease constitutes an environmental hazard and must be disposed in accordance with current regulations.

## REQUIREMENTS IN ADVANCE AND WHILE WORKING WITH THE MACHINE

Connect the Multi-Seeder in accordance with the requirements of the towing vehicle (risk of injury)

In the absence of protective covers and safety stickers the Multi-Seeder **NEVER** may be used.

Inspect the Multi-Seeder for loose bolts/nuts/parts before each use.

Make sure before you leave that you have both near and far visibility.

Before starting work, all persons who will operate the Multi-Seeder must be familiar with all the functions and controls of the machine.

**NEVER** crawl under the Multi-Seeder.

Tilt the Multi-Seeder if you need to have access to the underside of the machine.

**NEVER** get off the tractor while the engine is still running.

## SAFETYSTICKERS

On both sides of the Multi-Seeder, safety stickers (Figure 1 & 2) have been applied to the sideboards showing these warnings. Make sure these safety stickers are always clearly visible and legible. Replace them if they are damaged.

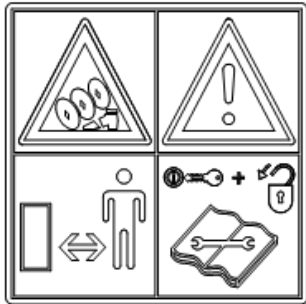

**Figure 1**

- When carrying out any maintenance activities, adjustments or repairs, **always switch off the tractor engine** first and **remove the tractor key** from the ignition.
- Keep a **minimal distance** of at least 4 meters (13 Ft)! (User excluded)
- No persons may be in the danger area if the machine while the machine is in operation, as there is a risk of injury from rotating parts.

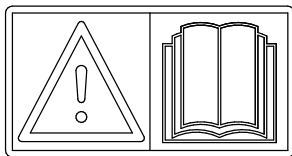

**Figure 2**

- All operators of the Multi-Seeder must **read the operating manual** and in particular the safety Instructions.

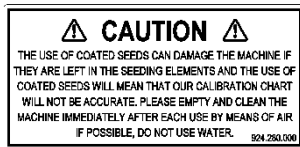

**924.280.000**

- Contamination of the seeding system can seriously damage the machine.  
Clean the machine thoroughly after each use, preferably using compressed air, not water.

## Safety decal locations

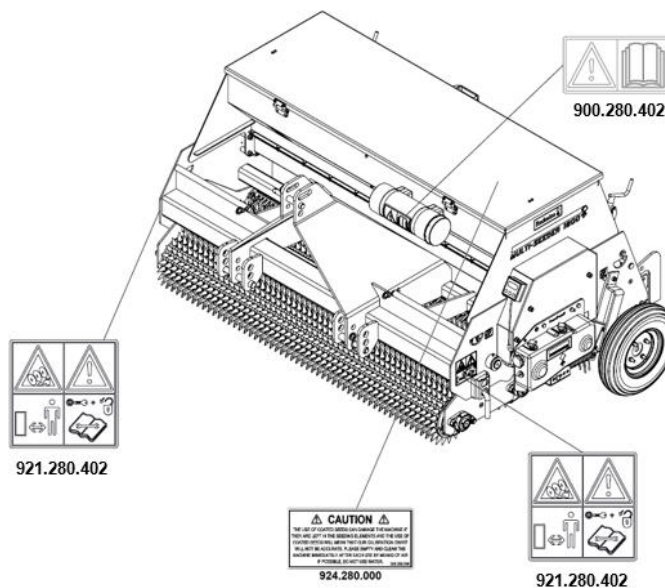

**Figure 3**

## CONTENTS

EU – DECLARATION OF CONFORMITY.....	2
UK – DECLARATION OF CONFORMITY .....	3
GUARANTEE CONDITIONS .....	4
REGISTRATION CARD .....	4
! SAFETY INSTRUCTIONS ! .....	5
1. TECHNICAL DATA .....	9
2. GENERAL DESCRIPTION.....	9
3. REMOVING THE MACHINE FROM THE PALLET .....	10
4. CONNECTING THE MULTI-SEEDER.....	11
4.1. CONNECTING.....	11
4.2. DISCONNECTING.....	12
5. TRANSPORTING THE MULTI-SEEDER .....	12
6. OPERATING THE MULTI-SEEDER.....	12
7. STARTING/STOPPING PROCEDURE .....	13
8. MACHINE SETTINGS .....	15
8.1. ADJUSTING THE SPIKED ROLLERS.....	15
8.2. ADJUSTING THE BRUSHES .....	16
8.3. ADJUSTING THE SEEDING ELEMENT VALVES.....	16
8.4. ADJUSTING THE AMOUNT OF SEED WITH THE GEARBOX .....	17
8.5. SPREADING TEST .....	18
9. TROUBLESHOOTING .....	21
10. MAINTENANCE .....	22
11. TECHNICAL INFORMATION: GREASEPOINTS .....	23
11.1. TECHNICAL INFORMATION: DIGITAL SURFACE METER.....	23
12. OPTIONS: WEIGHT KIT .....	24



## 1. TECHNICAL DATA

<u>Model</u>	<u>Multi-Seeder 1200</u>	<u>Multi-Seeder 1600</u>	<u>Multi-Seeder 2100</u>
Working width	1200mm (47.2")	1600mm (63")	2100mm (82.7")
Working depth	5 mm – 20 mm (0.2" – 0.8")		
Driving speed	Up to 12 km/h (7.5 mph)		
Hitch frame	CAT 1-2		
Weight	619kg (1365 lbs)	750kg (1653 lbs)	922kg (2033 lbs)
Capacity	150Ltr (5.3 cu. ft.)	200Ltr (7.1 cu. ft.)	270Ltr (9.5 cu. ft.)
Recommended tractor	25-48 HP with minimum lifting capacity of 910kg (2006 lbs)	35-60 HP with minimum lifting capacity of 1280kg (2822 lbs)	45-75 HP with minimum lifting capacity of 1650kg (3633 lbs)
Dimensions L x W x H	1323x1513x935mm (52.1"x59.6"x36.8")	1323x1682x935mm (52.1"x66.2"x36.8")	1323x2436x935mm (52.1"x95.9"x36.8")
Grease	EP 2		
Tyre pressure	1 – 2 bar (14.5 - 29 psi)		
Options	- Weight kit		

## 2. GENERAL DESCRIPTION

The Multi-Seeder is an overseeder for working on both fine turf and amenity type areas. The floating twin spike rollers follow the contours, saturating the surface with small holes. The amount of seed can be manual be adjusted to the required amount.

A drag brush sweeps the seeds into the holes, and a rear smooth roller firms up the surface.

### 3. REMOVING THE MACHINE FROM THE PALLET

Perform the following actions to remove the machine from the pallet and place it horizontally on the floor.

1. Attach a cable to the lifting points (1) on both sides of the machine (Figure 4).



**ENSURE THAT THE CABLE / CRANE COULD LIFT AT LEAST 2X WEIGHT OF THE MACHINE. (FOR WEIGHT SEE CHAPTER 1.0 TECHNICAL DATA)**

2. Lift the machine, including the pallet, about 100 mm (4") off the ground.
3. Remove the pallet by removing the bottom 3-point pins (2).
4. Pull the pallet away.
5. Lower the machine in a controlled and slow way until it is fully on the ground.



**!! STAY AT A SAFE DISTANCE, THE MACHINE CAN SLIDE !!**



**!! NEVER CRAWL UNDER THE MACHINE !!**

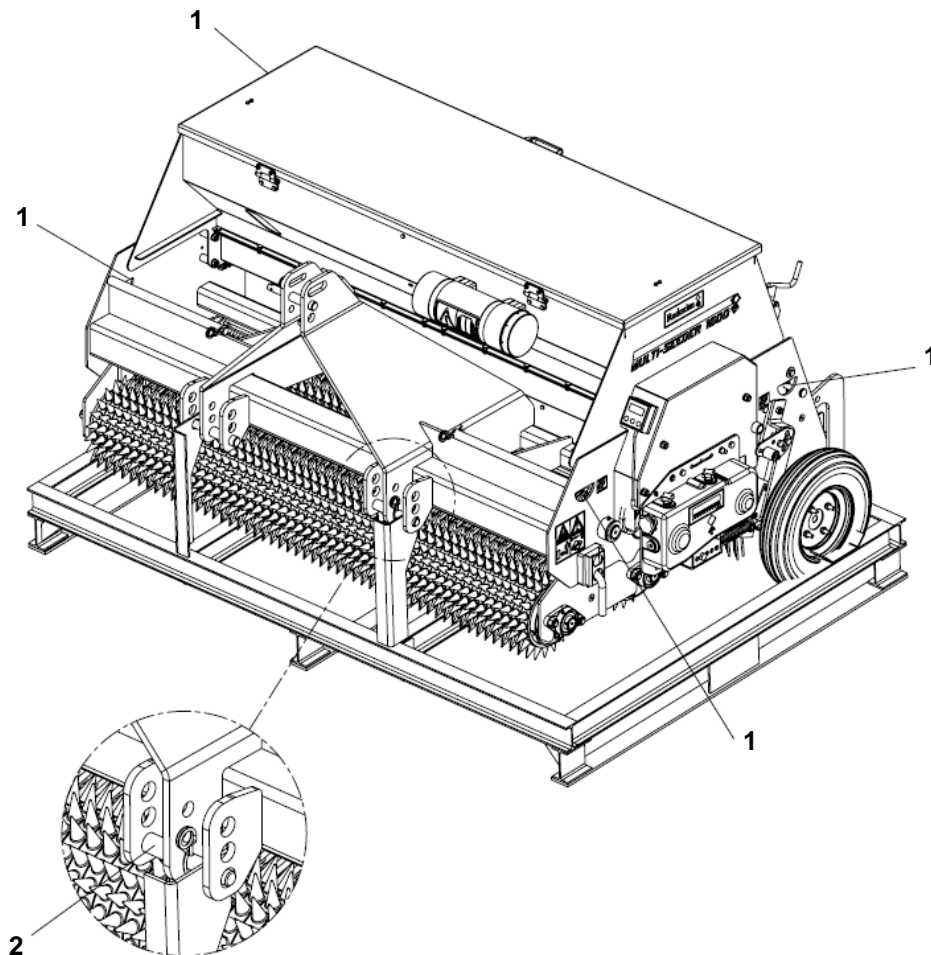

**Figure 4**

## 4. CONNECTING THE MULTI-SEEDER

For coupling and uncoupling of the Multi-Seeder you must proceed carefully. Follow the instructions below:

### 4.1. CONNECTING

Checks prior to connecting the Multi-Seeder:

- Check the Multi-Seeder for any visual damage, and repair if safe operation of the machine cannot be guaranteed.
- Check whether all nuts and bolts have been tightened properly.
- Check whether all protective covers and safety stickers are in place on the machine, and whether they are undamaged. **NEVER** use the machine without them.

The Multi-Seeder can be connected to the tractor using the 3-point hitch. The method is as follows (Figure 5):

1. Remove the 3-point pins (1).
2. Carefully back up the tractor, so that the lifting arms (2) can be connected to the frame.



**!! Make sure the tractor is secured in place and cannot start moving!!**



**!! Stop the engine of the tractor before getting off!!**

3. Connect the lifting arms (2) to the bottom 3-point pins (1) and secure them using the included locking pins.
4. Set the stabilizer of the tractor to a 100 mm sideways stroke.
5. Connect the top link (3) to the frame using the top pin (1) and secure using the included locking pin.
6. Keep extending/retracting the top link until the machine parallel with the ground.



**!! Make sure all locking pins are secured!!**

7. Start the tractor and lift the Multi-Seeder off the ground.

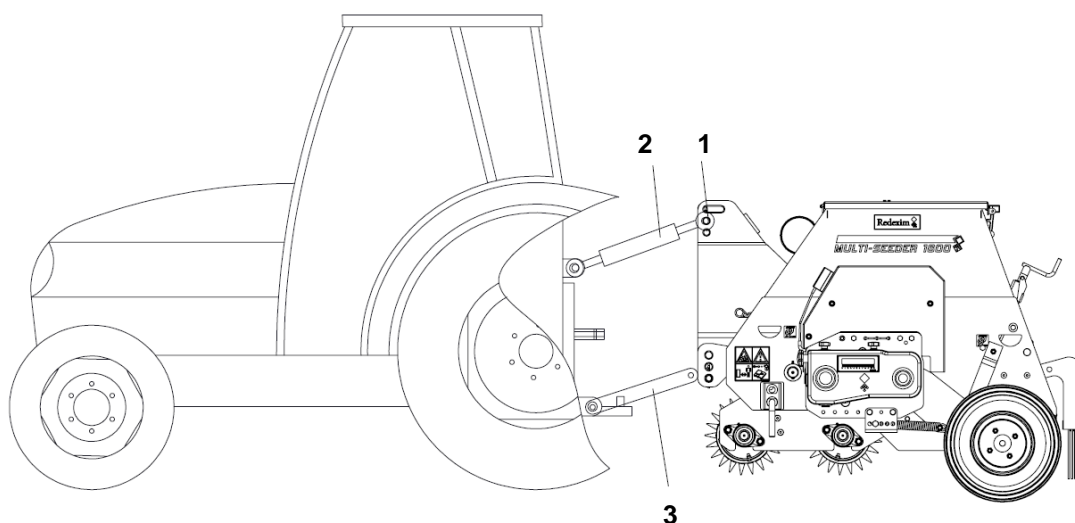

Figure 5

## 4.2. DISCONNECTING

The machine can be disconnected from the tractor as follows.

1. Drive the Multi-Seeder to a storage place with a stable/even floor.

 **If the machine is to be parked for an extended period of time, make sure it is in a dry environment.**

 **!! Make sure the tractor is secured in place and cannot start moving !!**

 **!! Turn the tractor off before dismounting !!**

 **!! Be sure that the Multi-Seeder is stable on the floor and can't move unintentionally before dismounting the tractor!!**

2. Slowly lower the machine until it stands on the ground.
3. Loosen the top link and remove it.
4. Disconnect the lower arms from the Multi-Seeder.

## 5. TRANSPORTING THE MULTI-SEEDER

The user is responsible for the transport of the Multi-Seeder behind the tractor when travelling on public roads. Check the national traffic rules. Due to the weight of the Multi-Seeder, a maximum speed of 20 km/h (12.4 mph) should be maintained while driving in open fields with the machine raised. Higher speeds may endanger the driver and/or other people and/or damage the machine.

 **When the Multi-Seeder has been lifted off the ground, at least 20% of the weight of the tractor must rest on the front axle.**

## 6. OPERATING THE MULTI-SEEDER

Before using the Multi-Seeder in the field, check the following:

1. Are there any loose objects in the field? Remove these first.
2. Are there any slopes? The maximum slope this machine can work on is 20 degrees.
3. Does the ground contain hard objects? If so, use the Multi-Seeder at a low speed and adjust the working depth.
4. Is there any danger of flying objects, which may distract the attention of the driver? If so, do **NOT** use the Multi-Seeder.
5. Is there any danger of sinking or sliding away? If so, postpone the work.
6. If the soil is frozen or very wet, the work should be postponed until the conditions are more favourable.
7. Check that the hopper is not too moist. Moisture can cause the seeds sticking together and provides a bad result.
8. Do not make sharp turns, preferably drive in straight lines to avoid damaging the machine and/or the ground.

**Some general remarks/tips on the use of the Multi-Seeder:**



**When hitting a hard object in the soil, the spiked rollers may be burred/damaged.**



**NEVER drive backwards while the running wheel is on the ground.**

## 7. STARTING/STOPPING PROCEDURE

Before starting to sow, check the machine on the following points:



**Make sure that the Multi-Seeder and tractor cannot move during adjustment.**



**Switch off the tractor engine.**

- Check that the shaft that drives the seed cups rotates smoothly. When the hopper is empty, the shaft (1) must be able to rotate with a wrench without too much force.

Rotate the shaft in the direction indicated by the arrow. (See Fig. 5-1)

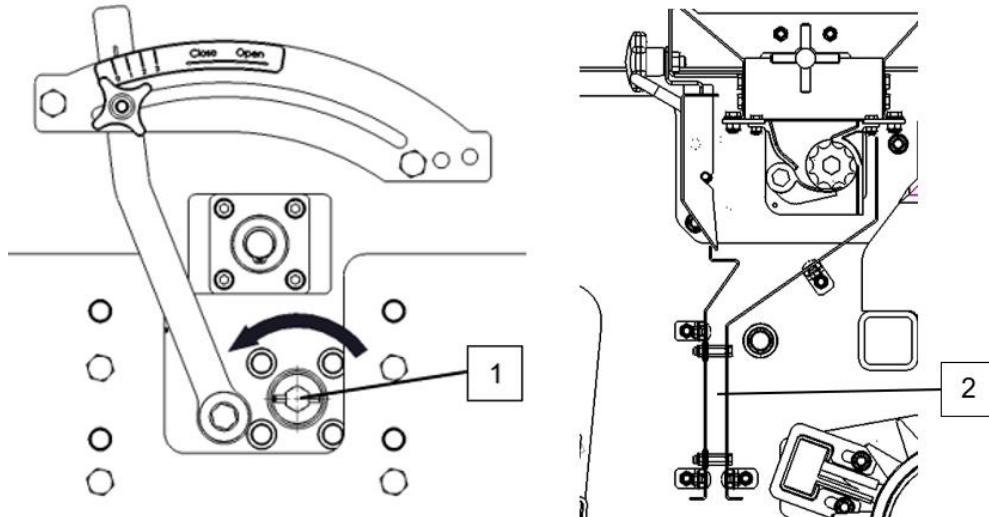

Fig. 5-1

If a heavy point is found, first check where it comes from and fix it. First of all, check for contamination of the sowing system and clean.

**Attention! If the shaft turns too heavily, a damaging overload of the gearbox can be the result.**

- Check that the seed passage (2) is not blocked. (Fig.5-1)
- Check that the machine is not damp, especially the sowing system. Check the sowing elements (1) for damage and repair if necessary. (Fig.5-2)

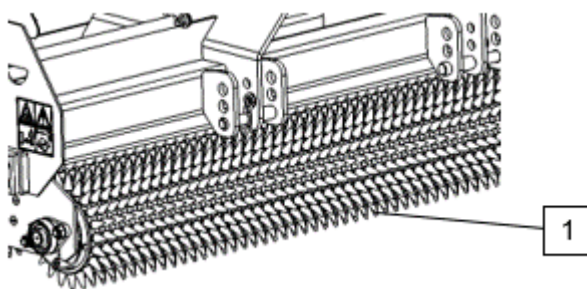

Fig.5-2

## START SEEDING.

The starting procedure is VERY important. If this procedure is not followed exactly as described below, serious damage may occur to the machine. The procedure is as follows:

1. Put the seed in the seed hopper.
2. Set the required seed quantity.



**While adjusting, the machine/tractor combination must be fully locked to prevent it from driving/sliding/sinking away. The tractor engine must be switched off.**

3. Drive to the place where you want to start.
4. While driving lower the machine carefully and in a controlled way until the spiked rollers are making holes in the ground.
5. Increase the speed until the correct driving speed has been reached.



**The driving speed while operating is limited to 12 km/h (7.5 mph). Higher speeds are not recommended and will result in excessive wear and damage to the machine.**

## STOP SEEDING

1. Lower the speed.
2. While driving, raise the machine out of the ground.
3. Go to the following place and start again as described.

## 8. MACHINE SETTINGS

The Multi-Seeder has several options to change the setup of the machine.

### 8.1. ADJUSTING THE SPIKED ROLLERS

The spiked rollers make holes in the ground for the seeds to fall into. These rollers follow the contours of the ground. Because of this a good result can be obtained even when the seed bed is uneven. When seeding on very hard ground the rollers can have difficulty penetrating the ground deep enough. To counter this, the rollers can be tilted so only the front roller makes contact with the ground. Because the weight of the machine pushes on only the front roller instead of two the holes will be deeper.

The following steps describe how the roller can be tilted (Figure 6):

1. Lift the machine of the ground

**⚠ !! Make sure the tractor is secured in place and cannot start moving !!**  
**⚠ !! Turn the tractor off before dismounting !!**

2. Remove the lock pin, left and right.
3. Tilted the frame
4. Place the pin the upper hole. Make sure the lock pin is secured.

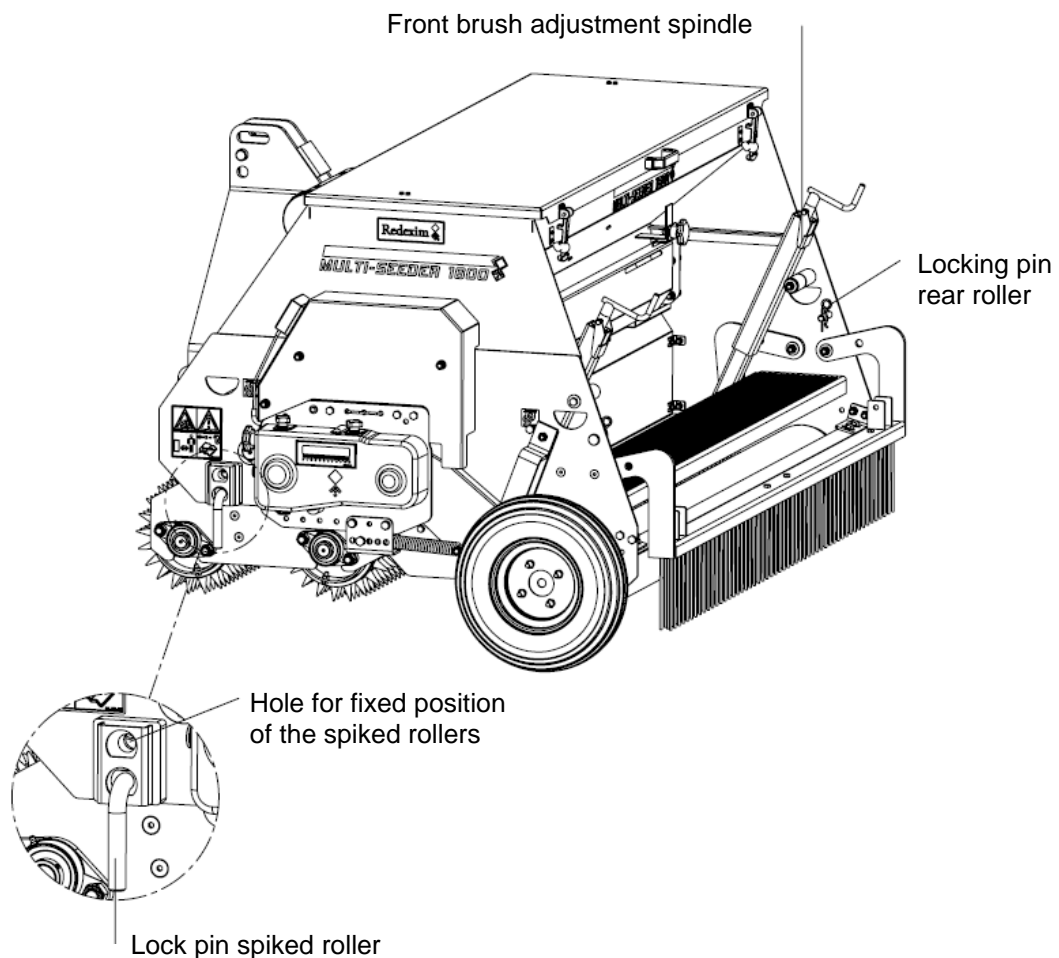

Figure 6

## 8.2. ADJUSTING THE BRUSHES

The Multi-Seeder has two brushes that brush. The front brush sweeps the seed in the holes. The rear brush sweeps soil in the holes to cover the seed.

The front most brush can be adjusted in height by using the spindles (Figure 6). Make sure the spindles are set at the same depth left & right.

It's possible to lock the rear brush by using the lock pins.

## 8.3. ADJUSTING THE SEEDING ELEMENT VALVES

The machine is suitable for the sowing of different types of seed. Also, the Multi-Seeder can be used in combination with various tractors and there can be a different in speeds. In order to adapt the machine to these various factors, the seed elements must be adjusted. The seed elements (Figure 8) have a number of functions:

1. If the valve is closed there is no seed flow from the hopper without running the machine, for example during transport.
2. To empty the hopper, the seed valve element can be put open so that the seed moves out of hopper. To collect the seed, you can mount the cover beam (See chapter 8.5)
3. The valve element can be adjusted to the size of the seed to be sown. With fine seed, the valve element must be completely closed. At larger seed, the space between the gear wheel and the valve is not large enough to allow the seeds through. For this reason the valve needs to be put open further. Adjusting the size of the opening can be done with the valve adjustment handle. The lever can be adjusted by loosening the knob (1) to select the desired position and tighten the knob again. (Figure 7)

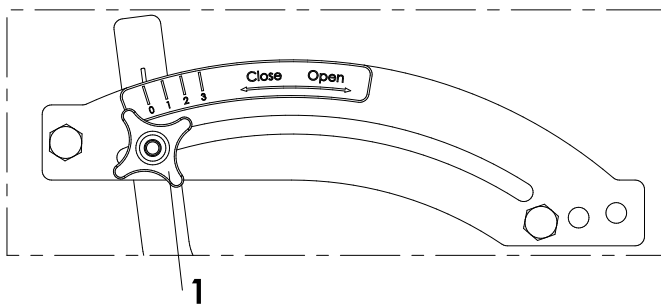

Figure 7

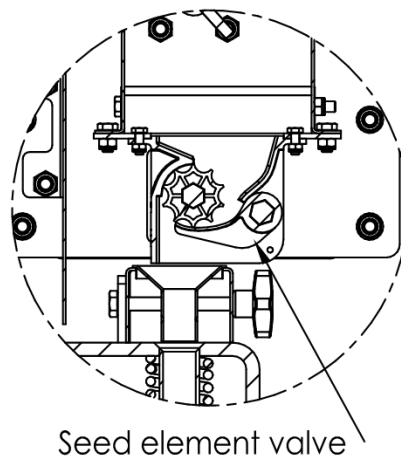

Figure 8



## 8.4. ADJUSTING THE AMOUNT OF SEED WITH THE GEARBOX

By adjustment the seed elements valve the amount of seed can be adjusted. I seed each element is a rotor that transports the seed. By influencing the speed of the gears, the quantity of seed can be adjusted. The speed can be infinitely adjusted with the gearbox. Proceed as follows to adjust the amount of seed at:

1. Loosen the knop (1) (Figure 9).
2. Turn the knob (2) to change the setting. The setting can be read on the label (3).  
See Table 1 for required amount of seed
3. Tighten the knop (1) again.

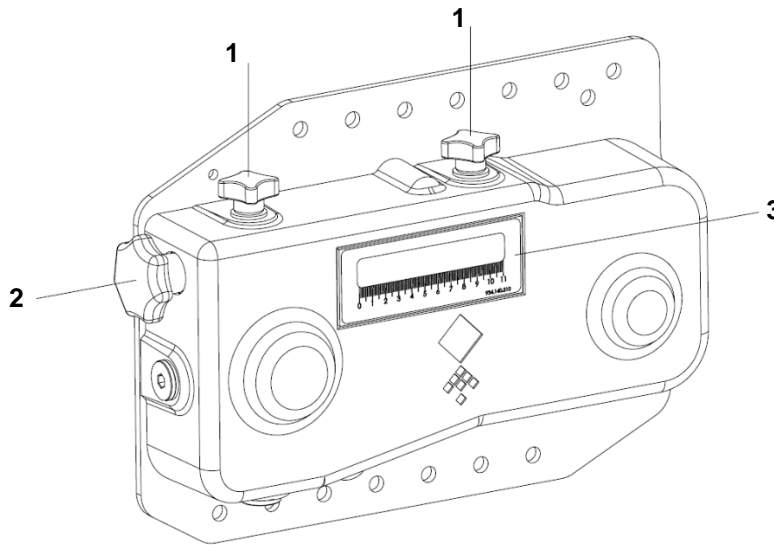

**Figure 9**

If the gearbox is set it maximum setting and there is not enough seed. The seed element valves can be readjusted (see section 8.3).

## 8.5 SPREADING TEST

If the seeding device needs recalibration for a certain seed type or if it must be checked for proper operation in accordance with the seed table 1, a spreading test is to be carried out. This is done as follows:



**!! Make sure the tractor and Multi-Seeder is secured in place and cannot start moving !!**



**!! Switch the tractor off before getting off !!**

To adjust the amount of seed the following resources are required:

1. A scale.
2. A container in which the seed can be weighed
3. Enough seed in order to fill the hopper for a minimum of 30%

Proceed as follows to check the amount of seed (Figure 10):

1. Lift the Multi-Seeder of the ground so that the wheel can rotate freely.
2. Remove the knurled screws (1) and the collecting tray(2).
3. Slide the collecting tray (2) under the seed elements.
4. Put the seed that is to be calibrated into the seed hopper and spread it equally in the hopper.
5. Turn the wheel (3) 13 full rotations counter clockwise



**!!Caution, at a high setting of the gearbox it may occur the collecting tray can spill. Divide the 13 rotations in more smaller steps!!**

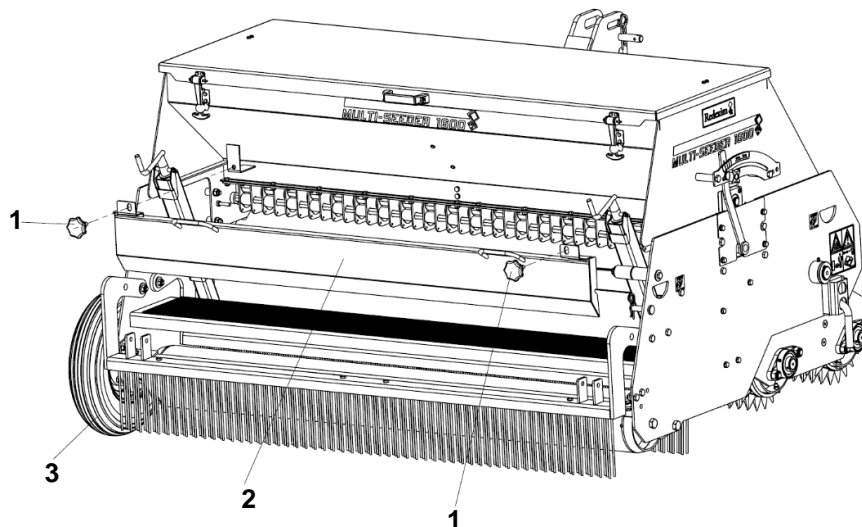

Figure 10

6. Weigh the seed in:

Kilograms and multiply the result by:

Multi-Seeder 1200: 512

Multi-Seeder 1600: 385

Multi-Seeder 2100: 293

The result is the amount of seeds in kilograms that should be spread per hectare. For a result in grams/m<sup>2</sup> divide the result by 10.

Pounds and multiply the result by:

Multi-Seeder 1200: 4.76

Multi-Seeder 1600: 3.57

Multi-Seeder 2100: 2.72

The result will give the amount of pounds seeded per 1000 sq.ft.

For a result in pounds/acre multiply the result with factor 43.56.

7. Install the seed bar on the Multi-Seeder.

**Seeding table Multi-Seeder 1200-1600-2100**

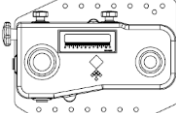
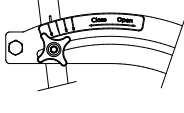
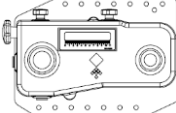
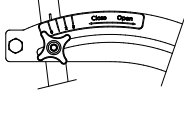
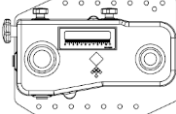
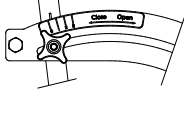
Gearbox setting 	Gate opening 	Rye grass			
		g/m <sup>2</sup>	Kg/ha	Pound / 1000 ft <sup>2</sup>	Pound / Acre
0.5	0	0.4	3.9	0.1	3.5
1	0	0.9	9.4	0.2	8.4
1.5	0	2.1	21.0	0.4	18.7
2	0	4.1	40.9	0.8	36.5
3	0	6.7	67.3	1.4	60.0
4	0	9.6	96.4	2.0	86.0
5	0	13.0	130.4	2.7	116.4
6	0	16.6	166.3	3.4	148.4
7	0	20.7	207.3	4.2	184.9
8	0	26.0	259.5	5.3	231.6
9	0	31.5	314.7	6.4	280.8
10	0	37.8	377.6	7.7	336.9
11	0	47.7	476.6	9.8	425.2
Gearbox setting 	Gate opening 	Blue grass			
		g/m <sup>2</sup>	Kg/ha	Pound / 1000 ft <sup>2</sup>	Pound / Acre
0.5	0	1.1	10.9	0.2	9.7
1	0	2.2	21.7	0.4	19.3
1.5	0	4.8	48.5	1.0	43.3
2	0	7.5	74.9	1.5	66.8
3	0	12.3	123.4	2.5	110.1
4	0	17.7	176.8	3.6	157.7
5	0	23.9	239.1	4.9	213.3
6	0	30.5	304.9	6.2	272.0
7	0	38.0	380.0	7.8	339.0
8	0	47.6	475.8	9.7	424.5
9	0	57.7	576.9	11.8	514.7
10	0	69.2	692.3	14.2	617.7
11	0	87.4	873.7	17.9	779.5
Gearbox setting 	Gate opening 	Red Fescue grass			
		g/m <sup>2</sup>	Kg/ha	Pound / 1000 ft <sup>2</sup>	Pound / Acre
0.5	0	0.5	5.5	0.1	4.9
1	0	1.1	10.8	0.2	9.7
1.5	0	2.4	24.3	0.5	21.6
2	0	3.7	37.5	0.8	33.4
3	0	6.2	61.7	1.3	55.1
4	0	8.8	88.5	1.8	78.9
5	0	12.0	119.6	2.5	106.7
6	0	15.3	152.5	3.1	136.1
7	0	19.0	190.1	3.9	169.6
8	0	23.8	238.1	4.9	212.4
9	0	28.9	288.7	5.9	257.6
10	0	34.6	346.4	7.1	309.1
11	0	43.7	437.2	9.0	390.1

**Seeding table Multi-Seeder 1200-1600-2100**

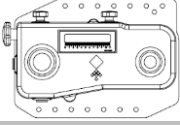
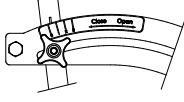
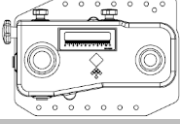
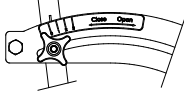
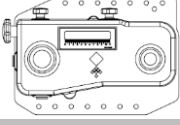
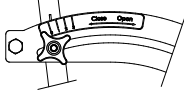
Gearbox setting 	Gate opening 	Bermuda grass			
		g/m <sup>2</sup>	Kg/ha	Pound / 1000 ft <sup>2</sup>	Pound / Acre
0.5	0	1.3	13.4	0.3	12.0
1	0	2.7	26.6	0.5	23.8
1.5	0	6.0	59.6	1.2	53.2
2	0	9.2	92.1	1.9	82.1
3	0	15.2	151.6	3.1	135.3
4	0	21.7	217.3	4.5	193.9
5	0	29.4	293.9	6.0	262.2
6	0	37.5	374.7	7.7	334.3
7	0	46.7	467.0	9.6	416.7
8	0	58.5	584.8	12.0	521.8
9	0	70.9	709.1	14.5	632.7
10	0	85.1	850.9	17.4	759.2
11	0	107.4	1073.9	22.0	958.1
Gearbox setting 	Gate opening 	Bent grass			
		g/m <sup>2</sup>	Kg/ha	Pound / 1000 ft <sup>2</sup>	Pound / Acre
0.5	0	0.9	8.8	0.2	7.9
1	0	1.7	17.5	0.4	15.6
1.5	0	3.9	39.1	0.8	34.9
2	0	6.0	60.5	1.2	53.9
3	0	10.0	99.6	2.0	88.8
4	0	14.3	142.7	2.9	127.3
5	0	19.3	193.0	4.0	172.2
6	0	24.6	246.1	5.0	219.6
7	0	30.7	306.7	6.3	273.7
8	0	38.4	384.1	7.9	342.7
9	0	46.6	465.7	9.5	415.5
10	0	55.9	558.9	11.4	498.6
11	0	70.5	705.4	14.4	629.3
Gearbox setting 	Gate opening 				
		g/m <sup>2</sup>	Kg/ha	Pound / 1000 ft <sup>2</sup>	Pound / Acre

## 9. TROUBLESHOOTING

<b>Problem</b>	<b>Possible cause</b>	<b>Solution</b>
The machine does not reach the required depth.	The ground is too hard	Aerate/irrigate
	Too little pressure on the front roll	Set the machine so that it rests on the front spiked roller only
	Not enough weight on the machine.	Mount extra weight on the machine
	Spikes are worn	Replace the spikes
The tractor does not have enough traction	Soil is too wet	Set the sowing
	Not enough weight on the machine.	Mount extra weight on the machine
There is no seed out of the machine.	Too wet seed causing it to stick	Use dry seed
	The gearbox is in the wrong position	Set the gearbox
	The lever to control the seed element valves is closed	Operate the lever to open the valve
	No seed in the hopper.	Controller whether there is sufficient seed in the hopper. Fill if necessary.
There is too much seed out of the machine.	The lever to control the seed element valves is fully opened	Operate the lever to close the valve

## 10. MAINTENANCE

Timeline	Checkpoint	Method
Before <b>every</b> usage	Check the shaft that drives the seed cups rotates smoothly.	See chapter 7. If the shaft rotates heavily, check for contamination and clean the seeding system.
	Check that the machine is not damp, especially the seeding system.	Dry the machine, use <b>only</b> air.
	Check for loose bolts/nuts.	Tighten the loose bolts/nuts to the correct torque.
	Presence and legibility of the safety decals.	Replace if not present/damaged.
After <b>every</b> usage	Clean the machine and especially the sowing mechanism.	Clean the seeding mechanism with air only. Do <b>not</b> use water.
	Store the machine in a dry environment.	
After the <b>first</b> 20 working hours. (new or repaired)	Check for loose bolts/nuts.	Tighten the loose bolts/nuts to the correct torque.
	Grease the grease points.	Use EP 2 grease. 1 shot
	Check that the drive chains have enough lubrication.	Lubricate the drive chains.
After <b>every</b> 100 hours	Check whether there is still enough grease/oil in the gearbox.	Top up the gearbox, see parts manual for details.
	Check that the drive chains have enough lubrication.	Lubricate the drive chains.
	Grease the grease points.	Use EP 2 grease. 1 shot

## 11. TECHNICAL INFORMATION: GREASEPOINTS

In order to guarantee a proper functioning of the Multi-Seeder, the grease points on both sides of the machine (Figure 11) have to be lubricated periodically. Lubricate the grease points according to the table in Chapter 10.

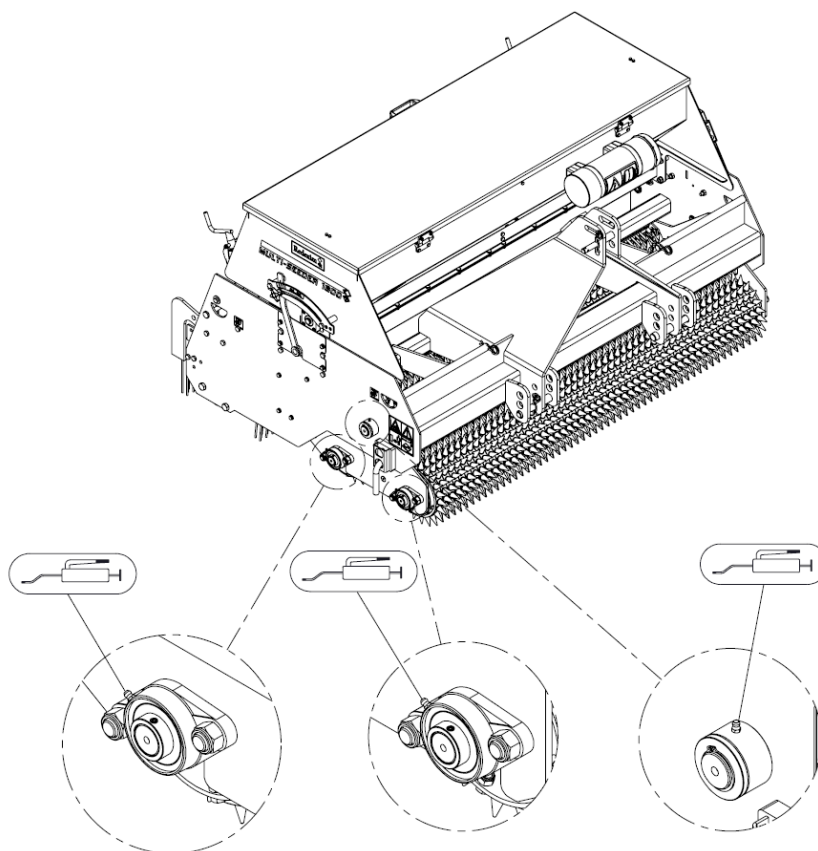

Figure 11

### 11.1. TECHNICAL INFORMATION: DIGITAL SURFACE METER

The machine can be equipped with a digital surface meter that can be used to read various data such as the machined area, distances, hours of work, etc.

For the explanation of the operation of this surface meter, a manual is included in the toolbox.

If the settings of the surface meter have disappeared from memory, these are the specific parameters to be filled in:

Machine	Parameter "C"	Parameter "L"	
	Pulses of the speed sensor (Chapter 8.2)	Working width (Chapter 8.4)	
	Setting UN=0 (metric); 1 (imperial)	m	ft
Multi-Seeder 1200	79	1.2	3.93
Multi-Seeder 1600	79	1.6	5.25
Multi-Seeder 2100	79	2.1	6.89

## 12. OPTIONS: WEIGHT KIT

The Multi-Seeder has a front beam to which the weights (1) can be attached. (Figure 12)

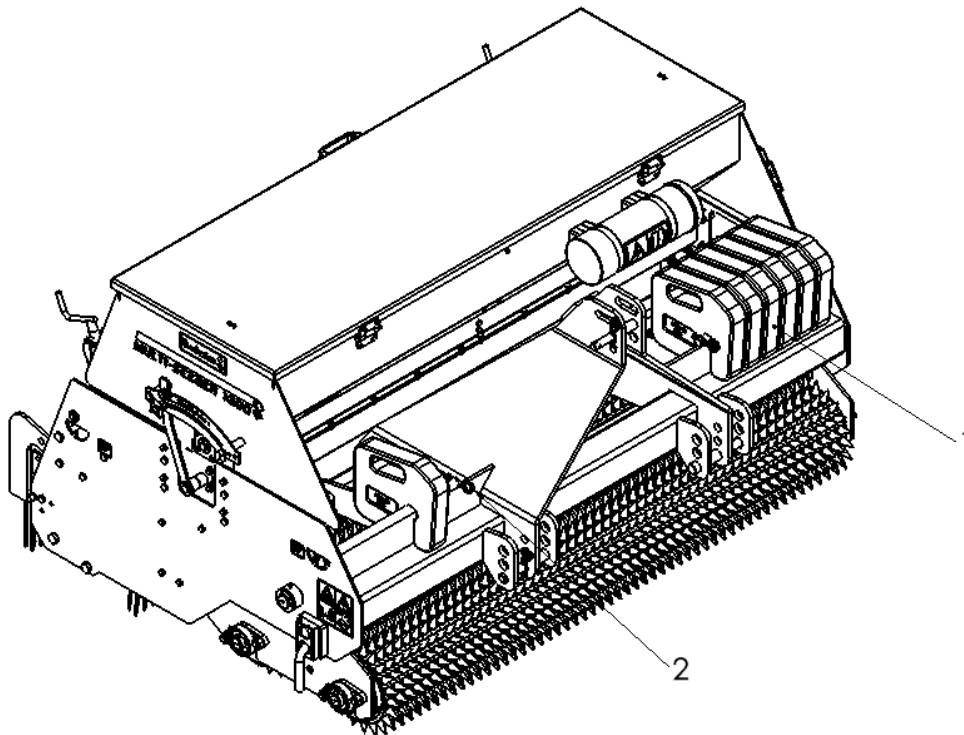

Figure 12

To mount the weights is to me as follows:

1. Remove the locking pin (2).
2. Mount the desired number of weights (1) onto the shaft.
3. Place the lock pin (2) onto the frame

Per machine, the following weights are available:

- Multi-Seeder 1200: 4x 492.502.800 (80Kg) (276 lbs)
- Multi-Seeder 1600: 12x 492.502.800 (240Kg) (528 lbs)
- Multi-Seeder 2100: 22x 492.502.800 (440Kg) (968 lbs)

### OTHER COMMENTS:



**ALWAYS FIX THE WEIGHTS ON THE MACHINE WITH THE SUPPLIED LOCKING PINS. IF THIS ISN'T DONE CORRECTLY THE WEIGHTS COULD FALL OFF THE MACHINE WHILE MOVING AND INJURE PEOPLE OR DAMAGE PARTS.**



**!! NEVER CRAWL UNDER THE MACHINE !!**



**!! SWITCH OFF THE TRACTOR BEFORE GETTING OFF !!**